

VARIABLE AREA TYPE FLOW METER (ROTAMETER)

P-TYPE

Applications

A. Measuring the flow rate for

- Chemical process system
- Water treatment system
- Industrial flow system

B. Service Condition

- Viscosity ≤ 3 cP
- Max working temperature: Metal: 100°C; Plastic: 60°C
- Max working pressure:
 - (1) Body material: PS, PI: 15 kg/cm², Plastic: 6 kg/cm²,
 - (2) Glass tube: 6 kg/cm²,
 - (3) P.C tube: 10 kg/cm², Instant pressure: 15 kg/cm²

C. Alarm switch available (N.O)

- Switch rating: AC 125V 0.5A / DC 100V 10W / Max. DC 250V < 1mA

D. Accuracy: ±2.5%F.S

Operation Principle

The variable area Flow meter contains a float & taper tube. The fluid flows through the taper tube and forces up to the float. The flow rate is measured as a function of the area of the opening. The flow rate increases as the float becomes free to move to produce the varying area.

Dimensions

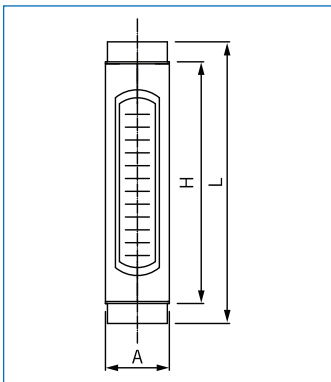

Range Size	H ₂ O (MAX) L/min	AIR (MAX) NL/min	DIMENSION			
			L	H	A	PT/NPT
6A	0.03 – 0.3	0.5 – 5.0	200	165	—	1/4"
10A	0.1 – 1.0	2 – 20	200	165	—	3/8"
15A	1 – 10	20 – 200	240	200	—	1/2"
20A	2 – 20	30 – 300	280	240	—	3/4"
25A	5 – 50	100 – 1000	280	240	—	1"
32A	10 – 100	200 – 2000	280	240	—	1 1/4"
40A	20 – 200	300 – 3000	305	240	—	1 1/2"
50A	40 – 400	500 – 5000	315	240	—	2"



Plastic

CE



Metal

CE

Ordering Information

P-TYPE	Code	Model	Code	Seal material
	PS	stainless steel wetted parts		(1) NBR (2) Viton
	PI	steel wetted parts		Code Protection Supporter material
	PV	plastic wetted parts		(1) SS304
		Code Size		(2) SS316
		(1) 6A (2) 10A (3) 15A (4) 20A		(3) Acrylic plastic
		(5) 25A (6) 32A (7) 40A (8) 50A		Code Flow range
		Code Connection thread (M–Male, F–Female)		L 0.03 ~ 400 L/min for liquid
		(1) PTM (2) PTF (3) NPTM (4) NPTF		G 0.5 ~ 5000 NL/min for gas
		Code Body (wetted parts) material		Code Alarm Switch
		(1) CS (2) SS304 (3) SS316		1R One setting point
		(4) SS316L (5) P.V.C. (6) P.P.		2R Two setting points
		(7) PVDF (8) Teflon		0 Without alarm
		Code Indicating Tube material		
		(1) Glass (2) PC (plastic)		
		Code Float material		
		(1) SS304		
		(2) SS316		
		(3) P.V.C		
		(4) P.P.		
		(5) Nylon		
		(6) PVDF		
		(7) Teflon		

NOTE
Special requests on materials are available.