

HORIZONTAL MAGNETIC LEVEL SWITCH

LT202 Flange Type *SQUARE FLANGE*

LT202 float-operated level switches are suitable for controlling liquid level at horizontal mounting. The float equipped with an extended arm moves a couple magnetic mechanism to actuate a microswitch to offer an ON-OFF contact for application.

Technical Data

Enclosure housing: Weather proof IP65

Material: Wetted parts SS316 or SS304

Temperature limits: -20°C to +150°C

Pressure limits: 3.0 MPa (30 kg/cm²), option: up to 4.5 MPa

Switch function: Micro switch 1 x SPDT; 2 x SPDT option

Switch rating: 3A/250VAC, 3A/30VDC, 0.4A/125VDC

Conduit connection: ½"NPT female, option

Float working specific gravity: ≥ 0.7 (option: less than 0.7 available on request)



Dimensions

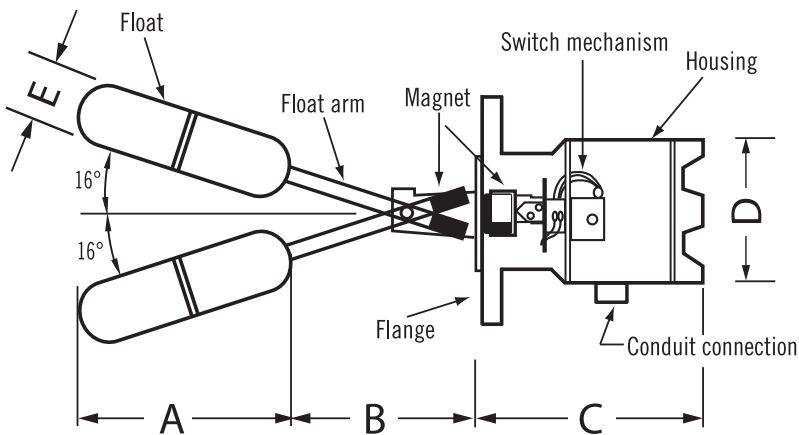

unit=mm

A	B	C	D	E
150	92	102 Approx.	64	40

NOTE. Special dimensions on request.
B: Extension length available.

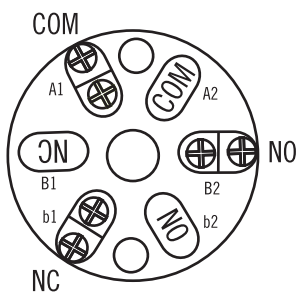
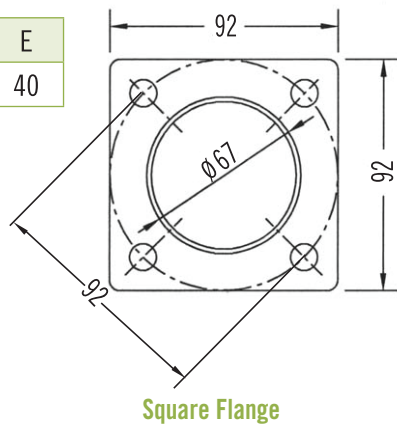

Wire Drawing

Accessory-Test Device

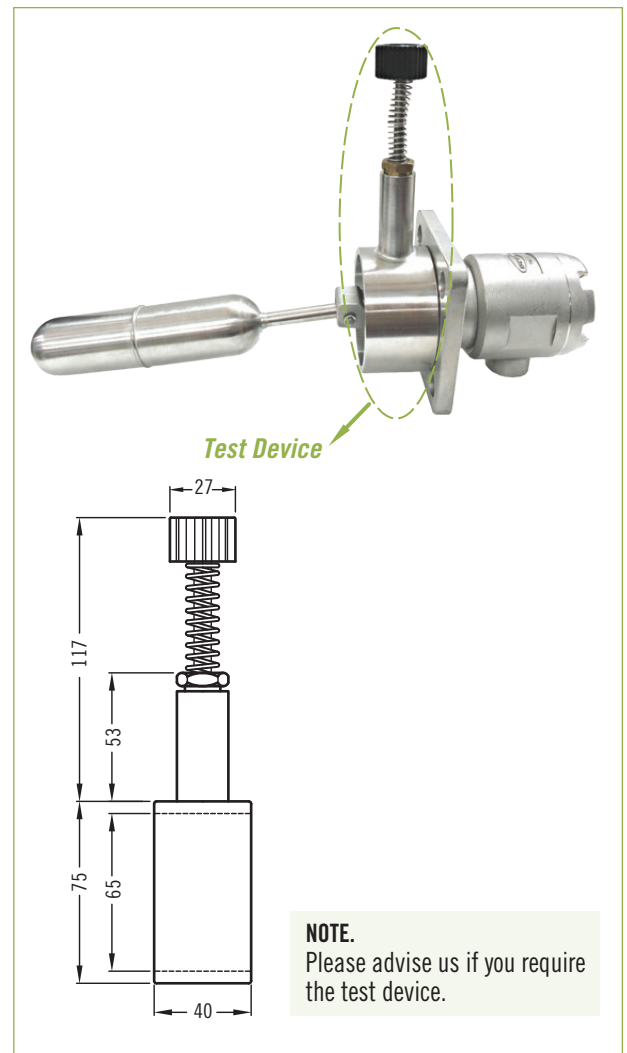

NOTE.
Please advise us if you require the test device.