

# Frequency/Rate Meter K3MA-F

## Highly Visible LCD Display with 2-color (Red and Green) LEDs

- Contact, NPN, PNP, or voltage pulse input.
- Front-panel key operation for easy setting.
- Average processing function suppresses flicker.
- Includes scaling, auto-zero time, startup compensation time functions.
- Easy confirmation of max/min display.
- Short 80-mm depth (measured from edge of face plate).
- Finger protective cover (standard equipment) guards against electric shock.
- Water- and dust-proof NEMA4X (IP66 equivalent) front panel.
- Recognized to U.S. and Canadian requirements under the Component Recognition Program of UL.
- CE marking.



## Model Number Structure

### Model Number Legend

K3MA-F-  -  -  

1    2    3

#### 1. Input Type

F: Rotary pulse

#### 2. Output Type

None: No output

A2: 2 relay contact outputs (SPST-NO)

#### 3. Supply Voltage

100-240VAC: 100 to 240 VAC

24VAC/VDC: 24 VAC/VDC

## Ordering Information

### List of Models

Input type	Supply voltage	Output	Model
Rotary pulse	100 to 240 VAC	None	K3MA-F 100-240VAC
		2 relay contact outputs (SPST-NO)	K3MA-F-A2 100-240VAC
	24 VAC/VDC	None	K3MA-F 24VAC/VDC
		2 relay contact outputs (SPST-NO)	K3MA-F-A2 24VAC/VDC

### Accessories (Order Separately)

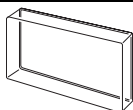
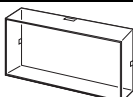
Name	Shape	Model
Splash-proof Soft Cover		K32-49SC
Hard Cover		K32-49HC



## ■ Characteristics

<b>Input signal</b>	No-voltage contact (30 Hz max., ON/OFF pulse width: 15 ms min.) Voltage pulse (5 kHz max., ON/OFF pulse width: 90 μs min., ON voltage: 4.5 to 30 V/OFF voltage: 0 to 2 V) Open collector (5 kHz max., ON/OFF pulse width 90 μs min.) <b>Connectable Sensors</b> ON residual voltage: 2.5 V max. OFF leakage current: 0.1 mA max. Load current: Must have switching capacity of 15 mA min. Must be able to dependably switch a load current of 5 mA max.
<b>Measuring accuracy</b>	±0.1%FS ±1 digit (at 23±5°C)
<b>Measurement method</b>	Cycle measurement
<b>Max. displayed digits</b>	5 digits (-19999 to 99999)
<b>Display</b>	7-segment digital display, Character height: 14.2 mm
<b>Polarity display</b>	"-" is displayed automatically with a negative input signal.
<b>Zero display</b>	Leading zeros are not displayed.
<b>Scaling function</b>	Programmable with front-panel key inputs (range of display: -19999 to 99999). The decimal point position can be set as desired.
<b>Hold function</b>	Max hold (maximum value), Min hold (minimum value)
<b>Hysteresis setting</b>	Programmable with front-panel key inputs (0001 to 9999).
<b>Other functions</b>	Scaling teach function Display color change (green (red), green, red (green), red) OUT type change (upper limit, lower limit, upper/lower limit) Average processing (simple average OFF/2/4/8 operations) Auto-zero time Startup compensation time Setting change lockout Parameter initialization Display auto-return time
<b>Output</b>	Relays: 2 SPST-NO
<b>Delay in comparative outputs</b>	750 ms max.
<b>Degree of protection</b>	Front panel: NEMA4X for indoor use (equivalent to IP66) Rear case: IEC standard IP20 Terminals: IEC standard IP00 + finger protection (VDE0106/100)
<b>Memory protection</b>	Non-volatile memory (EEPROM) (possible to rewrite 100,000 times)

## ■ Measuring Ranges

### No-voltage Contact/Open Collector Inputs

Input	Measuring range	Measuring accuracy	Displayable range
No-voltage contact (30 Hz max.) with ON/OFF pulse width of 15 ms min.	0.05 to 30.00 Hz	±0.1% FS ±1 digit max. (at 23±5°C)	-19999 to 99999 (with scaling function)
Open collector (5 kHz max.) with ON/OFF pulse width of 90 μs min.	0 to 5 kHz		

## ■ Input/Output Ratings

### Relay Contact Output

Item	Resistive load (cosφ = 1)	Inductive load (cosφ = 0.4, L/R = 7 ms)
<b>Rated load (UL ratings)</b>	5 A at 250 VAC, 5 A at 30 VDC	1.5 A at 250 VAC, 1.5 A at 30 VDC
<b>Rated carry current</b>	5 A max. (at COM terminal)	
<b>Max. contact voltage</b>	250 VAC, 150 VDC	
<b>Max. contact current</b>	5 A (at COM terminal)	
<b>Max. switching capacity</b>	1,250 VA, 150 W	250 VA, 30 W
<b>Min. permissible load (P level, reference value)</b>	10 mA at 5 VDC	
<b>Mechanical life</b>	5,000,000 times min. (at a switching frequency of 1,200 times/min)	
<b>Electrical life (at an ambient temperature of 20°C)</b>	100,000 times min. (at a rated load switching frequency of 10 times/min)	

# Connections

## Terminal Arrangement

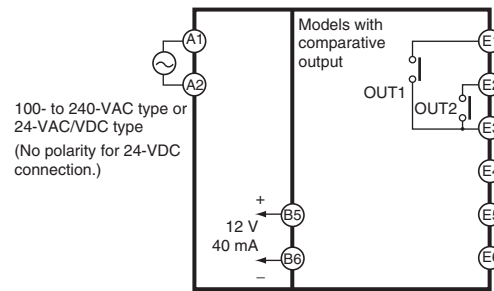
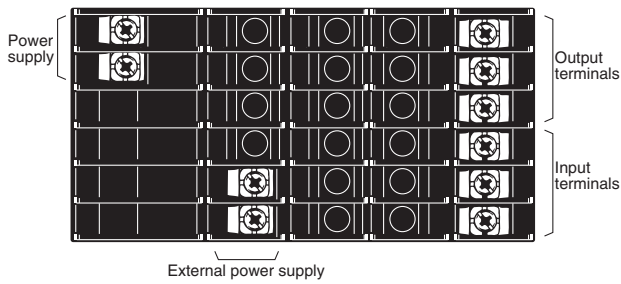

**Note:** Refer to *Input Circuits* on page 5.

Terminal No.	Name	Description
(A1) - (A2)	Operation power	Connects the operation power supply.
(E4), (E6) - (E5)	Pulse input	No-voltage contact/open collector input
(E1), (E2) - (E3)	Outputs	Outputs the relay outputs.
(B5) - (B6)	External power supply	Use as the power supply for sensors.

## Block Diagram

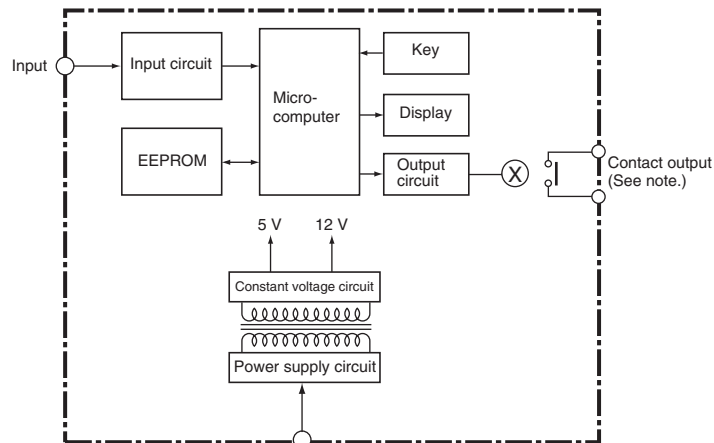

**Note:** Relay output models only.

## Input Circuits

### Pulse Input

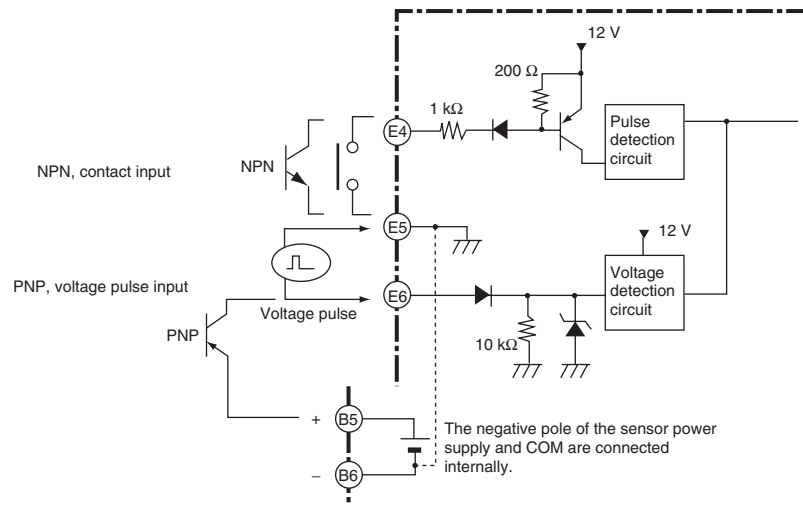

# Operation

## ■ Main Functions

### Input Types and Ranges

Frequency range (setting parameter)	Function	Input range (setting parameters)	Setting range
Pulse frequency selection (P-FRE)	Selects pulse input signal.	0.05 to 30.00 Hz (30)	Displayable from -19999 to 99999 with scaling function. The position of the decimal point can be set as desired.
		0 to 5 kHz (5μ)	

### Pulse Frequency Selection

Parameter	Setting value	Meaning
P-FRE	3	0.05 to 30.00 Hz measurement range
	5μ	0 to 5 kHz measurement range

**Note:** The default value is "0 to 5 kHz (5μ)."

### Scaling

When the desired display value is set for a corresponding input, the value will be displayed on a line between two points determining the zero point.

Parameter	Setting value	Meaning
INP	0 to 99999	Input value for dSP
dSP	-19999 to 99999	Display value for INP

Parameter	Setting value	Meaning
dP	0.0000	Display four digits after decimal point
	00.000	Display three digits after decimal point
	000.00	Display two digits after decimal point
	0000.0	Display one digit after decimal point
	00000	No decimal point

**Note:** The initial value will change depending on the pulse frequency selection.

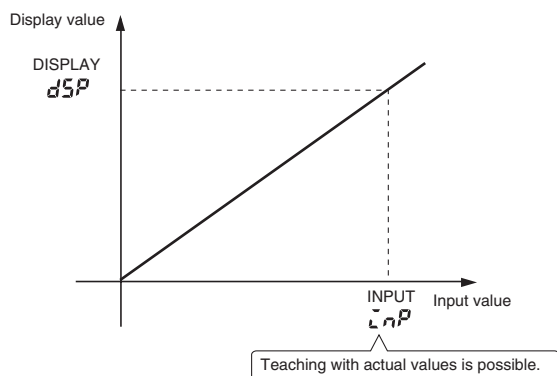

- The decimal point can be optionally displayed.
- When displaying the decimal point, consider the number of digits to follow the decimal point prior to setting the scaling display value.
- If P-FRE is set to 30, the initial setting for the decimal display will be 000.00.

Instead of setting by inputting with the Up Key and Shift Key, current values can be input as scaling input values for teaching. This is useful for making settings while checking the operation status of the K3MA-F.

## Convenient Functions

### Scaling Teach

The parameter (L<sub>RP</sub>) for the K3MA-F's initial setting level can be set using actual input values with the teaching function. After displaying the parameter, the actual input settings can be made with the following operation.

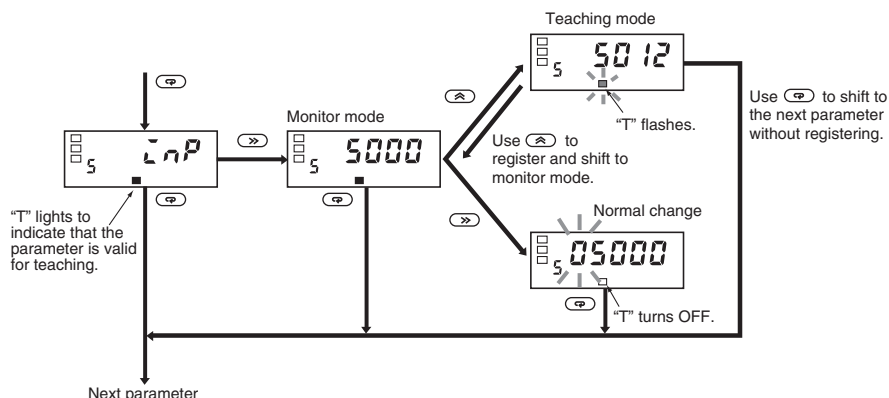

## OUT Types (Comparative Output Models Only)

OUT 1 and OUT 2 can be set to operate in one of the three following modes in accordance with the compared values:

- Upper limit (High Acting):  
The output is turned ON when the measurement value is greater than its set value.
- Lower limit (Low Acting):  
The output is turned ON when the measurement value is less than its set value.
- Upper and lower limits (Outside Band Acting):  
An upper limit (H set value) and lower limit (L set value) can be set independently.  
The output is turned ON when the measurement value is greater than upper-limit set value or less than the lower-limit set value.

### Upper Limit (High Acting)

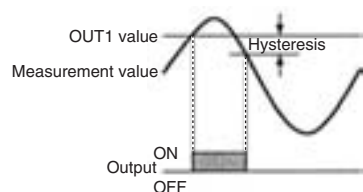

### Lower Limit (Low Acting)

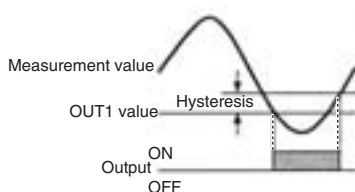

### Upper and Lower Limits (Outside Band Acting)

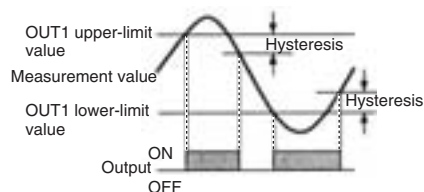

The three types of output operations shown above can be combined as desired. The following are examples of possible combinations.

### Upper Limit 2-stage Output

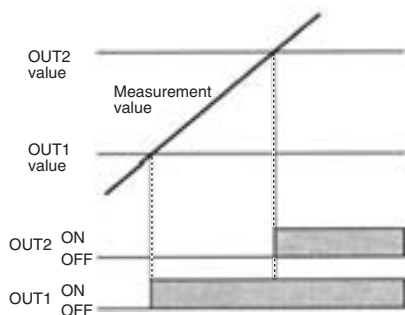

### Threshold Output

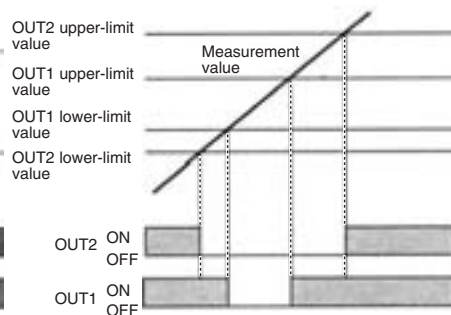

### Combination of Upper Limit and Upper/Lower Limits

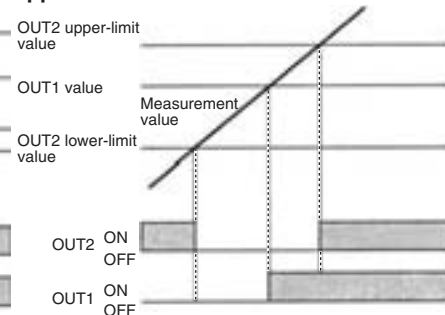

## Parameter Initialization

This function returns all of the parameters to their initial values.

Parameter	Setting value	Meaning
L <sub>RP</sub>	OFF	---
	ON	Initializes all parameters.

Use this to reset the K3MA-F after returning it to its factory-set condition.

## Average Processing

Average processing stabilizes the display by minimizing any pulsating or flicker caused by fluctuations in the pulse width of sensor input or by eccentricity in rotating shafts.

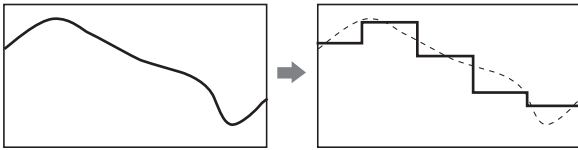

## Hysteresis (Comparative Output Models Only)

The hysteresis of comparative outputs can be set to prevent chattering in the output when the measurement value fluctuates finely near the OUT value.

### Upper limit (high acting)

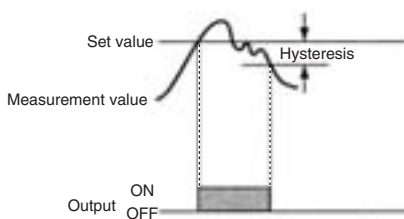

## Auto-zero Time

This function sets the time for the display to return to zero when input pulses stop. Set the time longer than the expected input pulse cycle (the interval between one input pulse and the next). Proper measurement is not possible if the time is set shorter than the input pulse cycle.

## Startup Compensation Time

The startup compensation time cancels measurement for a predetermined time when turning power ON, to prevent unwanted output due to temporary input fluctuations.

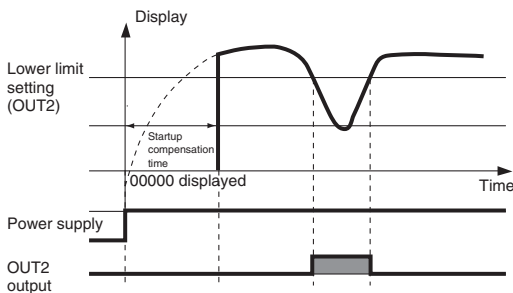

## Changing the Display Color

The color of the value displayed can be set to either red or green. For comparative output models, the display color can be set to change from green to red, or from red to green, according to the status of the comparison criterion.

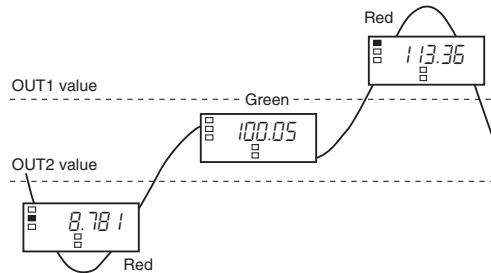

## Display Auto-return Time

This function automatically returns the display to the operation level's current value if no keys are pressed for a preset time (called the display auto-return time).

## Move-to-Protect-Level Time

The time required to shift to the protect level can be set as desired.

## MAX/MIN Display

The maximum and minimum measurement (display) values from the time the power is turned ON until the current time can be stored and displayed. This is useful, for example, when measuring the maximum value.

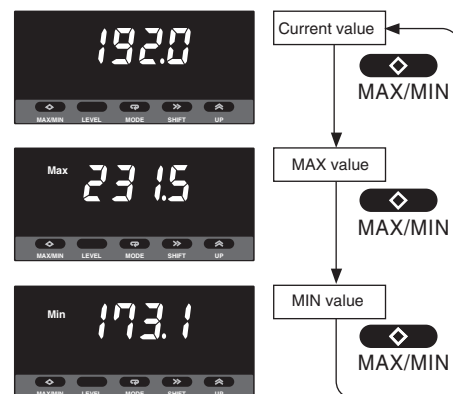



# Nomenclature

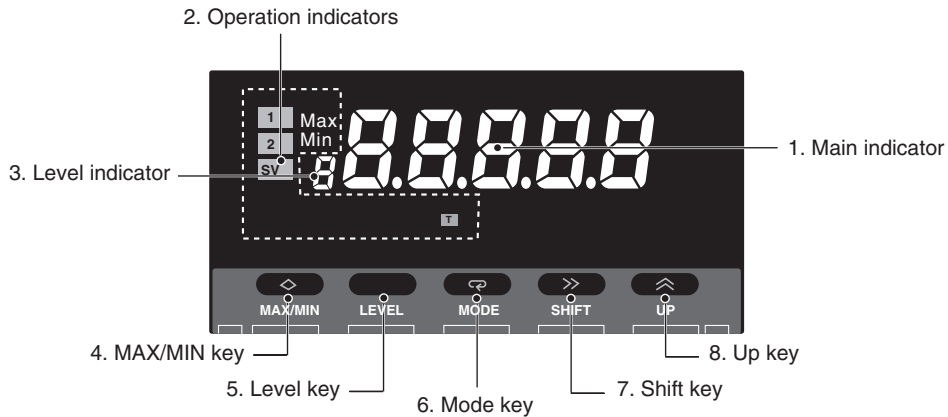

Name	Functions	
1. Main indicator	Displays current values, parameters, and set values.	
2. Operation indicators	1	Lit when output 1 is ON.
	2	Lit when output 2 is ON.
	SV	Lit when a set value is being displayed or changed.
	Max	Lit when the main indicator is showing the MAX value.
	Min	Lit when the main indicator is showing the MIN value.
	T	Lit when the teaching function is operable. Blinks while the teaching function is operating.
3. Level indicator	Displays the current level that the K3MA-F is in. (See below for details.)	
4. MAX/MIN Key	Used to display the MAX and MIN values when a measurement value is being displayed.	
5. Level Key	Used to change the level.	
6. Mode Key	Used to allow the main indicator to indicate parameters sequentially.	
7. Shift Key	Used to enable a set value to be changed. When changing a set value, this key is used to move along the digits.	
8. Up Key	Used to change a set value. Used to set or clear a forced-zero function when a measurement value is being displayed.	

Level indicator	Level
$\bar{P}$	Protect
Not lit	Operation
$\zeta$	Initial setting
$\bar{F}$	Advanced-function setting

## Dimensions

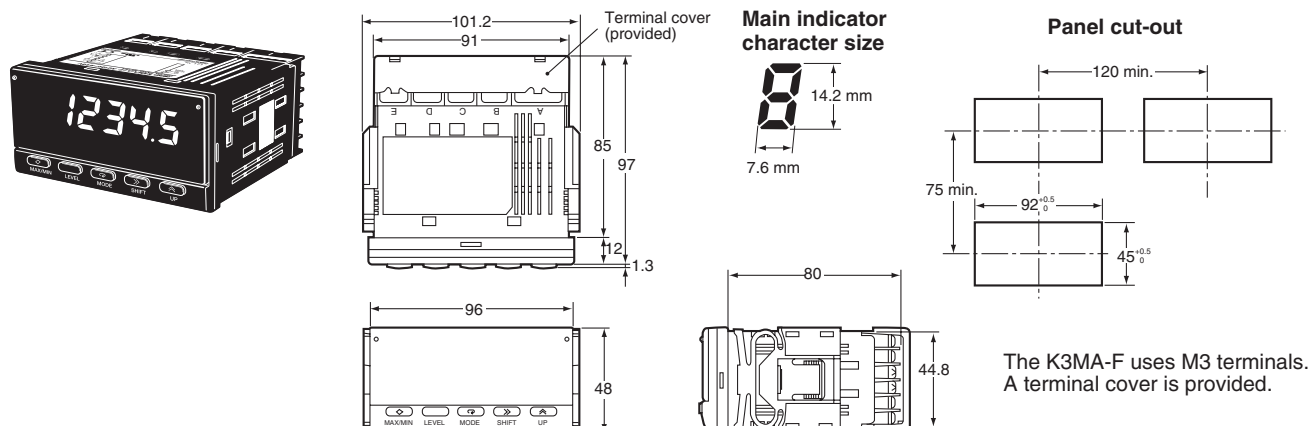

## Application Examples

### Displaying conveyor belt feed speed

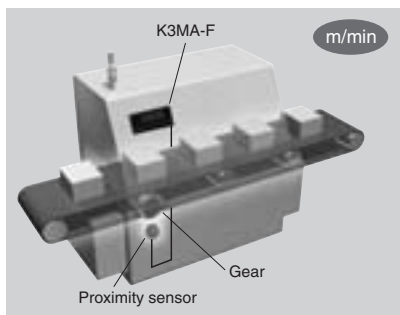

- Monitoring line speed for a reflow furnace
- Displaying feed speed for food processing, conveying, sintering

### Monitoring the rotations of a mixer or churner

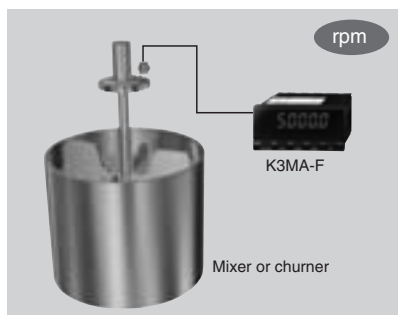

- Mixers for resin molding
- Powdering/pelleting machines, centrifugal separators

### Displaying the monitor output from an inverter as rotations or line speed

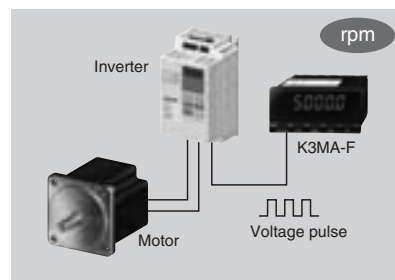

**Note:** If the monitor output from the inverter is analog, such as 0 to 10 V, use the K3MA-J.

- Monitoring conveyor speed
- Machining equipment (grinders, polishers)

# Installation

1. Insert the K3MA-F into the panel cut-out hole.
2. For a waterproof installation, insert the rubber gasket onto the body of the K3MA-F.

**Note:** For scales and gauges, use the unit labels that are specified by the relevant laws or regulations.

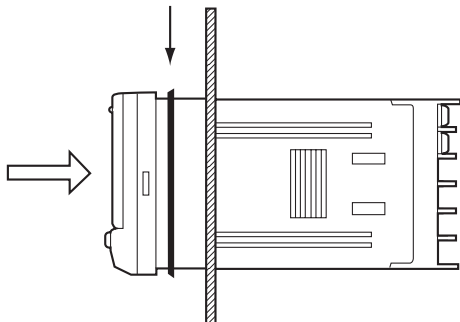

3. Fit the adaptor into the grooves on the left and right sides of the rear case, then push it until it contacts the panel to secure the K3MA-F.

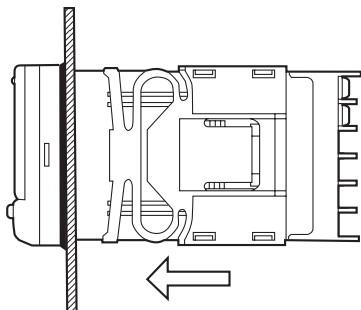

## Wiring Precautions

- Use crimp terminals.
- Tighten the terminal screws to a torque of approximately 0.5 N·m.
- To avoid the influence of noise, route signal lines and power lines separately.

## Wiring

- Use the following M3 crimp terminals.

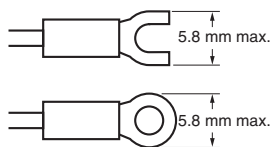

## Unit Labels (Provided)

- The unit labels are not attached to the K3MA-F. Select the desired labels from the provided sheet.

V	A	V	A	%	J	Pa	Ω
s	/	N	m	W	°C	m <sup>3</sup>	k
°F	g	min	mm			rpm	
VA	mV	mA				Hz	
m/min	OMRON						
OUT	OUT						

## Precautions



### WARNING

Do not touch any of the terminals while the power is being supplied. Doing so may result in electric shock.



### Caution

Do not disassemble the product or touch the internal components of the product while the power is being supplied. Doing so may result in electric shock.



### Caution

Do not allow metal objects or wire cuttings to enter the product. Doing so may result in electric shock, fire, or malfunction.



### Caution

Perform correct settings for the product according to the control application. Failure to do so may cause unexpected operation, resulting in damage to the product or injury.



### Caution

Take safety measures, such as installing a separate monitoring system, to ensure safety even if the product fails. Product failure may prevent comparative outputs from being generated, resulting in serious accidents.

Observe the following precautions to ensure safety.

1. Maintain the power supply voltage within the range specified in the specifications.
2. Maintain the load within the ratings specified in the specifications.
3. Check each terminal for correct number and polarity before connecting it. Incorrect or reverse connections may damage or burn out internal components in the product.
4. Tighten the terminal screws securely. The recommended tightening torque is 0.43 to 0.58 N·m. Loose screws may cause fire or malfunction.
5. Do not connect anything to unused terminals.
6. Provide a switch or circuit breaker so that operators can easily turn OFF the power supply when necessary. Also provide appropriate indications of such devices.
7. Do not attempt to disassemble, repair, or modify the product.
8. Do not use the product where flammable or combustible gases are present.

## Application

### General Precautions

1. Do not use the product in the following locations:
  - Locations subject to direct radiant heat from heating equipment.
  - Locations subject to exposure to water, oil, or chemicals.
  - Locations subject to direct sunlight.
  - Locations subject to dust or corrosive gases (particularly sulfuric gas or ammonia gas).
  - Locations subject to severe changes in temperature.
  - Locations subject to icing or condensation.
  - Locations subject to shock or vibration.
2. Do not block heat dissipation around the product, i.e., provide sufficient space for heat dissipation.
3. Ensure that the rated voltage is reached within two seconds after the power is turned ON.
4. Conduct aging for 15 minutes min. after power is turned ON for correct measurement.

5. Do not touch the slit sections or terminals while the power is being supplied to prevent the product from being affected by static electricity.
6. Do not lay heavy objects on the product during use or storage. Doing so may deform or deteriorate the product.
7. Do not use paint thinner for cleaning. Use commercially available alcohol.

### Mounting

- Mount the product to a panel that is 1 to 8 mm thick.
- Install the product in a horizontal position.
- Use crimp terminals that match screw sizes.

### Noise Prevention

- Install the product as far as possible from devices that generate strong, high-frequency fields (such as high-frequency welders or sewing machines) or surges.
- Install surge absorbers or noise filters on nearby devices that generate noise (particularly motors, transformers, solenoids, magnet coils, and other devices that have a high inductance component).

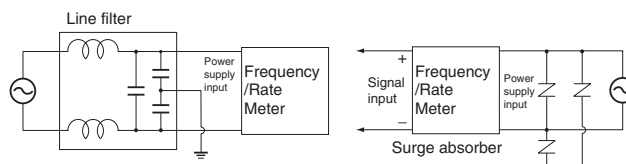

- To prevent inductive noise, separate the terminal block wiring for the product from high-voltage or high-current power lines. Do not route the wiring for the product in parallel with or tie it in a bundle with power lines.
- When using a noise filter for the power supply, check for the voltage and current and install it as close as possible to the Frequency/Rate Meter.
- Do not install the product near radios, television sets, or wireless devices. Doing so may cause reception interference.

### Increasing Service Life

- Do not use the product in locations where the temperature or humidity exceeds the ratings or where condensation may occur. When installing the product in a panel, be sure that the temperature around the product (not the temperature around the panel) does not exceed the ratings. The product service life depends on the ambient temperature. The higher the ambient temperature, the shorter the service life. To extend the product service life, lower the temperature inside the Frequency/Rate Meter.
- Use and store the product within the temperature and humidity ranges given in the specifications. When gang-mounting Frequency/Rate Meters or arranging them vertically, heat generated by the Frequency/Rate Meters will cause the internal temperature to rise, reducing the service life. In such cases, consider forced cooling methods, such as using a fan to circulate air around the Frequency/Rate Meters. Do not, however, allow only the terminals to be cooled. Doing so will increase measurement error.
- The life of the output relays is greatly affected by the switching capacity and switching conditions. Use these relays within their rated load and electrical life. The contacts may fuse or burn if they are used past their electrical life.



## Parameters

- Note:**
1. Some parameters are not displayed for certain models.
  2. The K3MA-F will stop measurement if the level is changed to the initial setting level or the advanced-function setting level.
  3. If the input range is changed, some parameters are set to default values. Therefore, set the input range first.
  4. Settings displayed in reversed colors are defaults.

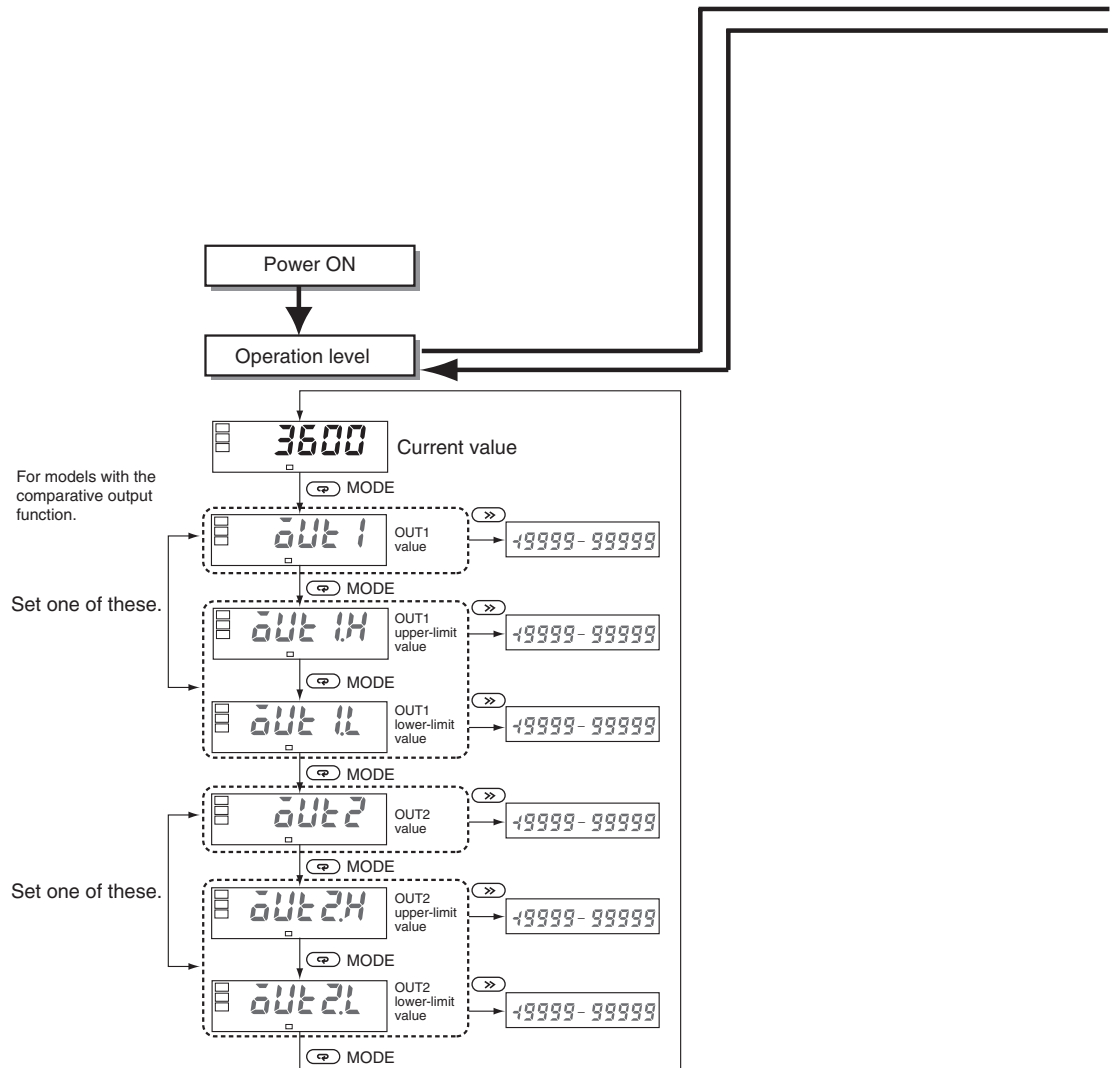

Press Level Key  $\square$  for more than 3 s.

Press Level Key  $\square$  for less than 1 s.

Press Level Key  $\square$  for less than 1 s.

Models with the comparative output function

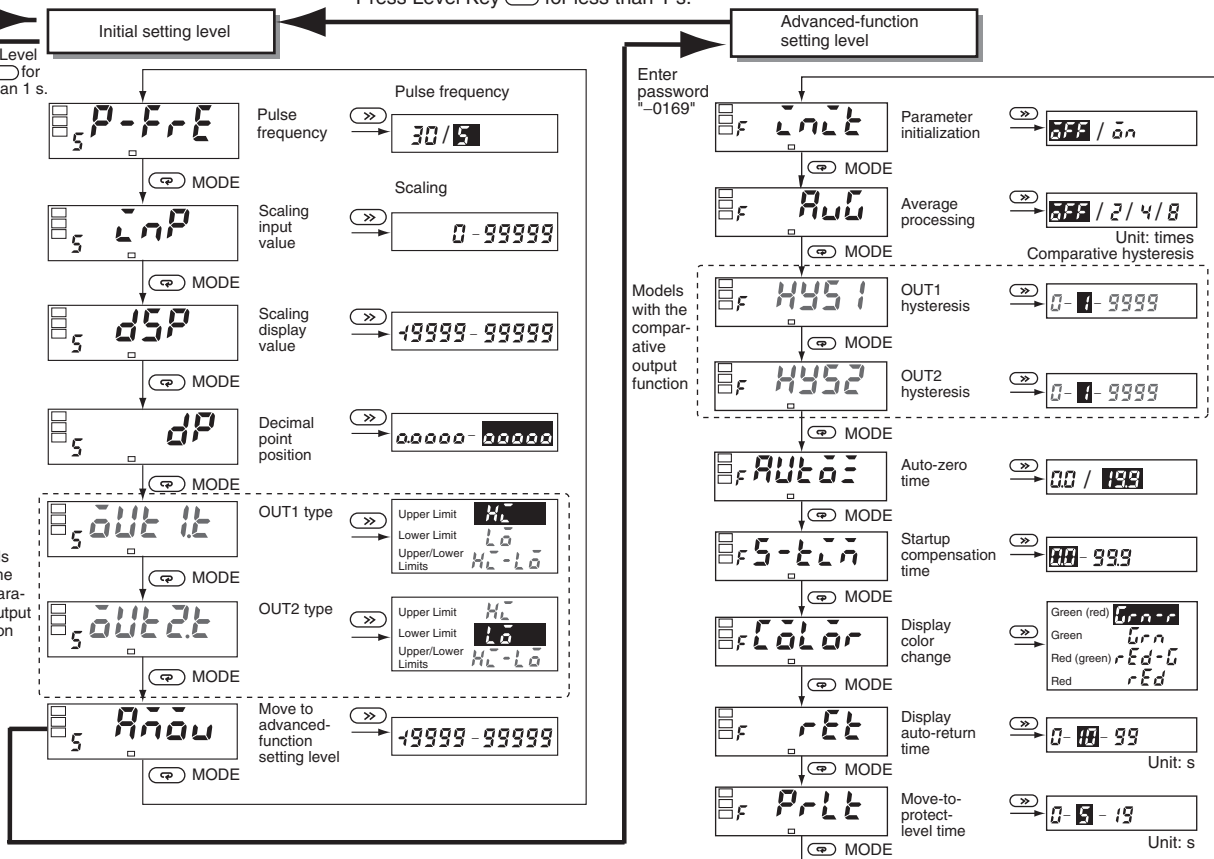

Settings displayed in reversed colors are initial settings.

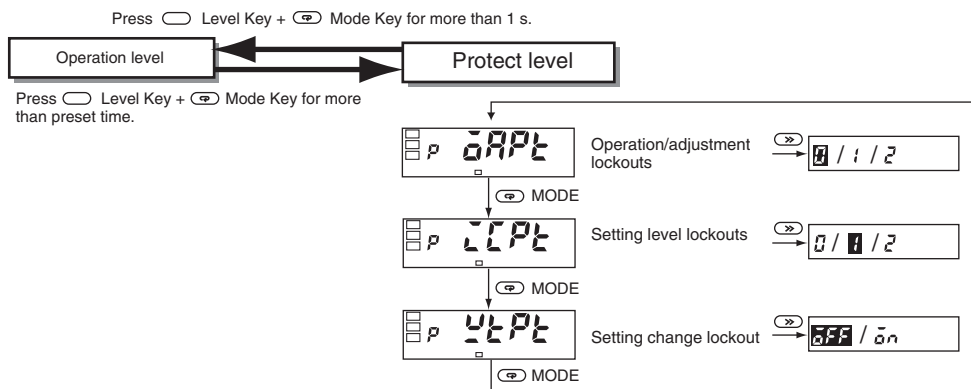

## Operation/Adjustment Lockouts

Restricts key operations for operation level and adjustment level.

Parameter	Setting	Operation level	
		Current value display	Set value display
0ARPt	0	Allowed	Allowed
	1	Allowed	Allowed
	2	Allowed	Prohibited

- Initial setting is 0.
- This is not displayed on models with no comparative output function.

## Setting Level Lockouts

Restricts shifting to initial setting level or advanced-function setting level.

Parameter	Setting	Shift to initial setting level	Shift to advanced-function setting level
1CPt	0	Allowed	Allowed
	1	Allowed	Prohibited
	2	Prohibited	Prohibited

## Setting Change Lockout

Restricts setting changes by key operation. When this lockout is set, it is no longer possible to shift to a setting change mode.

Parameter	Setting	Setting change by key operation
2LPt	0FF	Allowed
	0n	Prohibited

However, all protect level parameters can still be changed.

## Initial Settings

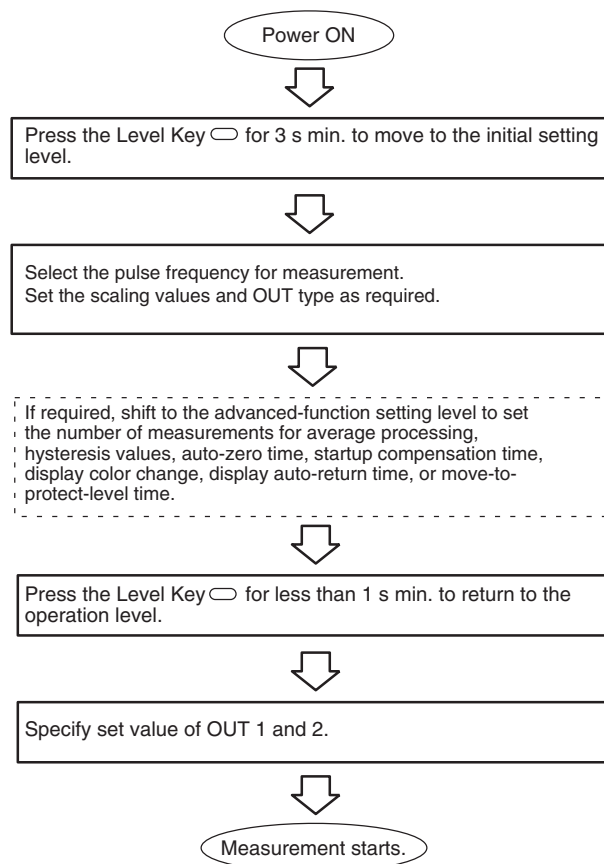



## Setting Example

### Initial Settings

The settings for the following example are shown here.

#### Example: Display conveyor belt feed speed

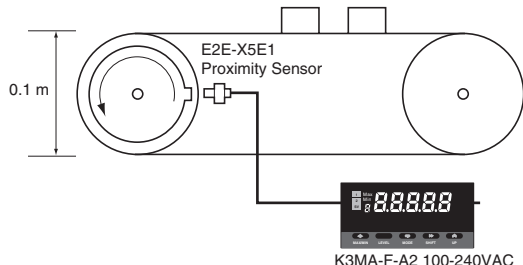

Here, the conveyor belt feed speed is to be displayed in units of 0.1 m/min.

- Proximity Sensor: E2E-X5E1, NPN output

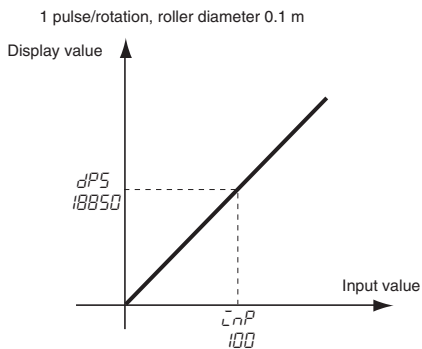

When displaying a flowrate (e.g., in //min or //h), make the scaling settings after confirming the I/O characteristics of the flowrate sensor. There are flowrate sensors that output analog signals. If this kind of flowrate sensor is used, consider using the K3MA-J.

- Select the maximum input frequency for the K3MA-F. Set the pulse frequency selection to either 30 Hz or 5 kHz. In the example, this is set to 30 Hz because the conveyor belt is turning at a slow speed.  
Parameter: *P-FrE* (pulse frequency), Setting value: 30
- Set the scaling. The relationship between the display value and the input value is shown in the following equation.  

$$\text{Rotations (rpm)} = \text{Frequency input/No. of pulses per rotation} \times 60$$

$$\text{Cycle speed D (m/min)} = \text{Rotations} \times \text{roll circumference} = 1/N \times f \times 60 \times d \times \pi$$

N: No. of pulses per rotation  
f: Frequency (Hz)  
d: Roller diameter (m)

When the input conditions are applied to this equation, we obtain the following:

$$\text{Display value} = 1/1 \times f \times 60 \times 0.1 \times \pi$$

For an input of 1 Hz, the display value is 18.8495 (m/min).

The scaling settings for the K3MA-F must be integers. Also, to decrease error, the scaling value is multiplied by 1,000, to obtain an input of 1000 Hz and a display value of 18850. However, because the display value in this case is displayed to the first decimal place, the scaling is set as shown in the following example so that 18850 is displayed for an input of 100 Hz.

Parameter	Setting value
<i>dNP</i> (scaling input value)	100
<i>dSP</i> (scaling display value)	18850
<i>dP</i> (decimal point position)	0000.0

**Note:** The decimal point position here refers to the position in the number after scaling. When setting the scaling display value, it is necessary to consider the number of digits to be displayed past the decimal point.

## Troubleshooting

When an error occurs, error details will be displayed on the main indicator. Confirm the error from the main indicator and take the appropriate countermeasures.

Level display	Main indicator	Error contents	Countermeasures
Not lit	E 111	RAM memory error	Repair is necessary. Consult your OMRON sales representative.
5	E 111	EEPROM memory error	When this error is displayed, press the Level Key for 3 seconds, and the settings will be restored to the factory settings. If the error cannot be recovered, repair is necessary. Consult your OMRON sales representative.
Not lit	Flashes 99999	The scaling display value exceeds 99999.	Promptly change the input to a value that falls within the specified range. The scaling value may be inappropriate. Review the scaling value at the initial setting level.
Not lit	Flashes -19999	The scaling display value is lower than -19999.	Promptly change the input to a value that falls within the specified range. The scaling value may be inappropriate. Review the scaling value at the initial setting level.

## Warranty and Limitations of Liability

---

### ■ WARRANTY

OMRON's exclusive warranty is that the products are free from defects in materials and workmanship for a period of one year (or other period if specified) from date of sale by OMRON.

OMRON MAKES NO WARRANTY OR REPRESENTATION, EXPRESS OR IMPLIED, REGARDING NON-INFRINGEMENT, MERCHANTABILITY, OR FITNESS FOR PARTICULAR PURPOSE OF THE PRODUCTS. ANY BUYER OR USER ACKNOWLEDGES THAT THE BUYER OR USER ALONE HAS DETERMINED THAT THE PRODUCTS WILL SUITABLY MEET THE REQUIREMENTS OF THEIR INTENDED USE. OMRON DISCLAIMS ALL OTHER WARRANTIES, EXPRESS OR IMPLIED.

### ■ LIMITATIONS OF LIABILITY

OMRON SHALL NOT BE RESPONSIBLE FOR SPECIAL, INDIRECT, OR CONSEQUENTIAL DAMAGES, LOSS OF PROFITS, OR COMMERCIAL LOSS IN ANY WAY CONNECTED WITH THE PRODUCTS, WHETHER SUCH CLAIM IS BASED ON CONTRACT, WARRANTY, NEGLIGENCE, OR STRICT LIABILITY.

In no event shall the responsibility of OMRON for any act exceed the individual price of the product on which liability is asserted.

IN NO EVENT SHALL OMRON BE RESPONSIBLE FOR WARRANTY, REPAIR, OR OTHER CLAIMS REGARDING THE PRODUCTS UNLESS OMRON'S ANALYSIS CONFIRMS THAT THE PRODUCTS WERE PROPERLY HANDLED, STORED, INSTALLED, AND MAINTAINED AND NOT SUBJECT TO CONTAMINATION, ABUSE, MISUSE, OR INAPPROPRIATE MODIFICATION OR REPAIR.

## Application Considerations

---

### ■ SUITABILITY FOR USE

OMRON shall not be responsible for conformity with any standards, codes, or regulations that apply to the combination of products in the customer's application or use of the products.

At the customer's request, OMRON will provide applicable third party certification documents identifying ratings and limitations of use that apply to the products. This information by itself is not sufficient for a complete determination of the suitability of the products in combination with the end product, machine, system, or other application or use.

The following are some examples of applications for which particular attention must be given. This is not intended to be an exhaustive list of all possible uses of the products, nor is it intended to imply that the uses listed may be suitable for the products.

- Outdoor use, uses involving potential chemical contamination or electrical interference, or conditions or uses not described in this catalog.
- Nuclear energy control systems, combustion systems, railroad systems, aviation systems, medical equipment, amusement machines, vehicles, safety equipment, and installations subject to separate industry or government regulations.
- Systems, machines, and equipment that could present a risk to life or property.

Please know and observe all prohibitions of use applicable to the products.

NEVER USE THE PRODUCTS FOR AN APPLICATION INVOLVING SERIOUS RISK TO LIFE OR PROPERTY WITHOUT ENSURING THAT THE SYSTEM AS A WHOLE HAS BEEN DESIGNED TO ADDRESS THE RISKS, AND THAT THE OMRON PRODUCTS ARE PROPERLY RATED AND INSTALLED FOR THE INTENDED USE WITHIN THE OVERALL EQUIPMENT OR SYSTEM.



ALL DIMENSIONS SHOWN ARE IN MILLIMETERS.  
To convert millimeters into inches, multiply by 0.03937. To convert grams into ounces, multiply by 0.03527.

Cat. No. N107-E1-03A In the interest of product improvement, specifications are subject to change without notice.

---

**OMRON Corporation**  
Industrial Automation Company

Industrial Devices and Components Division  
H.Q.

**Measuring Components Department**

Shiokoji Horikawa, Shimogyo-ku,  
Kyoto, 600-8530 Japan  
Tel: (81)75-344-7080/Fax: (81)75-344-7189

Printed in Japan  
0204-0.5M (1001) (A)

# Process Meter K3MA-J

## Highly Visible LCD Display with 2-color (Red and Green) LEDs

- Multi-range DC voltage/current input.
- Front-panel key operation for easy setting.
- Average processing function suppresses flicker.
- Scaling, front-panel forced-zero, zero-limit functions.
- Easy confirmation of max/min display.
- Short 80-mm depth (measured from edge of face plate).
- Finger protective cover (standard equipment) guards against electric shock.
- Water- and dust-proof NEMA4X (IP66 equivalent) front panel.
- Recognized to U.S. and Canadian requirements under the Component Recognition Program of UL.
- CE marking.



## Model Number Structure

### Model Number Legend

K3MA-J- - 

1    2    3

#### 1. Input Type

J: DC voltage/current

#### 2. Output Type

None: No output

A2: 2 relay contact outputs (SPST-NO)

#### 3. Supply Voltage

100-240VAC: 100 to 240 VAC

24VAC/VDC: 24 VAC/VDC

## Ordering Information

### List of Models

Input type	Supply voltage	Output	Model
DC voltage/current	100 to 240 VAC	None	K3MA-J 100-240VAC
		2 relay contact outputs (SPST-NO)	K3MA-J-A2 100-240VAC
	24 VAC/VDC	None	K3MA-J 24VAC/VDC
		2 relay contact outputs (SPST-NO)	K3MA-J-A2 24VAC/VDC

### Accessories (Order Separately)

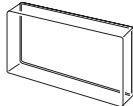
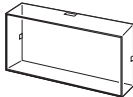
Name	Shape	Model
Splash-proof Soft Cover		K32-49SC
Hard Cover		K32-49HC



## ■ Characteristics

Input signal	DC voltage/current (0 to 20 mA, 4 to 20 mA, 0 to 5 V, 1 to 5 V, $\pm 5$ V, $\pm 10$ V)
A/D conversion	Double integral method
Sampling period	250 ms
Display refresh period	Sampling period (sampling times multiplied by number of measurements for averaging if average processing is selected.)
Max. displayed digits	5 digits (-19999 to 99999)
Display	7-segment digital display, Character height: 14.2 mm
Polarity display	"-" is displayed automatically with a negative input signal.
Zero display	Leading zeros are not displayed.
Scaling function	Programmable with front-panel key inputs (range of display: -19999 to 99999). The decimal point position can be set as desired.
Hold function	Max. hold (maximum value), Min. hold (minimum value)
Hysteresis setting	Programmable with front-panel key inputs (0001 to 9999).
Other functions	Forced-zero (with front-panel key) Zero-limit Scaling teach function Display color change (green (red), green, red (green), red) OUT type change (upper limit, lower limit, upper/lower limit) Average processing (simple average)
Output	Relays: 2 SPST-NO
Delay in comparative outputs	750 ms max.
Degree of protection	Front panel: NEMA4X for indoor use (equivalent to IP66) Rear case: IEC standard IP20 Terminals: IEC standard IP00 + finger protection (VDE0106/100)
Memory protection	Non-volatile memory (EEPROM) (possible to rewrite 100,000 times)

## ■ Measuring Ranges

### Process Voltage/Current Inputs

Input	Measuring range	Measuring accuracy	Input impedance	Displayable range
DC voltage	1.000 to 5.000 V	$\pm 0.1\%$ FS $\pm 1$ digit max. (at $23 \pm 3^\circ\text{C}$ )	1 M $\Omega$ min.	-19999 to 99999 (with scaling function)
	0.000 to 5.000 V			
	-5.000 to 5.000 V	$\pm 0.1\%$ FS $\pm 1$ digit max. (at $23 \pm 5^\circ\text{C}$ )		
	-10.00 to 10.00 V			
DC current	4.00 to 20.00 mA/ 0.00 to 20.00 mA	$\pm 0.1\%$ FS $\pm 1$ digit max. (at $23 \pm 3^\circ\text{C}$ )	45 $\Omega$	

## ■ Input/Output Ratings

### Relay Contact Output

Item	Resistive load ( $\cos\phi = 1$ )	Inductive load ( $\cos\phi = 0.4$ , L/R=7 ms)
Rated load (UL ratings)	5 A at 250 VAC, 5 A at 30 VDC	1.5 A at 250 VAC, 1.5 A at 30 VDC
Rated carry current	5 A max. (at COM terminal)	
Max. contact voltage	250 VAC, 150 VDC	
Max. contact current	5 A (at COM terminal)	
Max. switching capacity	1,250 VA, 150 W	250 VA, 30 W
Min. permissible load (P level, reference value)	10 mA at 5 VDC	
Mechanical life	5,000,000 times min. (at a switching frequency of 1,200 times/min)	
Electrical life (at an ambient temperature of $20^\circ\text{C}$ )	100,000 times min. (at a rated load switching frequency of 10 times/min)	

# Connections

## Terminal Arrangement

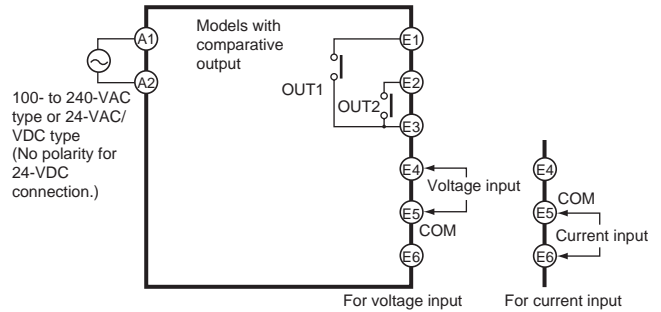
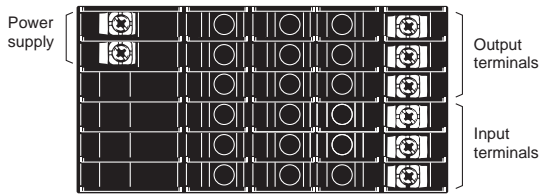

Terminal No.	Name	Description
(A1) - (A2)	Operation power	Connects the operation power supply.
(E4) (E6) - (E5)	Analog input	Connects the voltage or current analog input.
(E1) (E2) - (E3)	Outputs	Outputs the relay outputs.

## Block Diagram

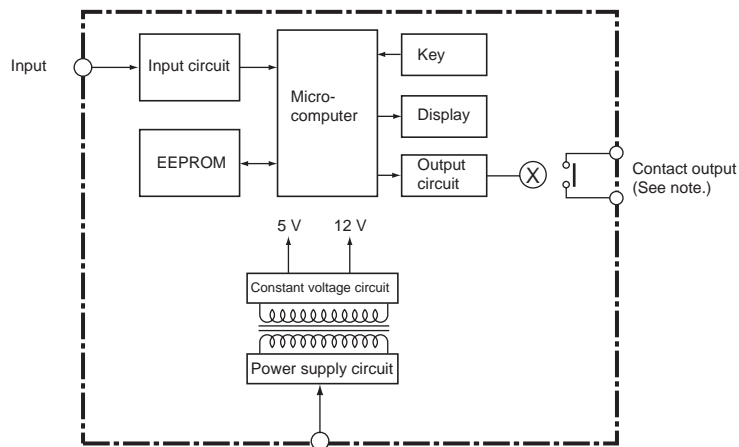

Note: Relay output models only.

## Input Circuits

### Analog Input (DC Voltage/Current)

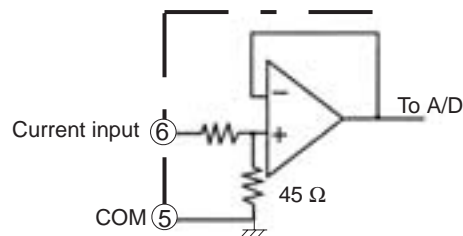
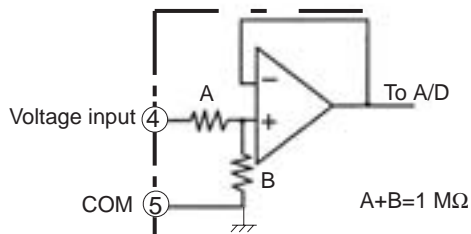



# Operation

## ■ Main Functions

### Input Types and Ranges

Input type (setting parameter)	Function	Input range (setting parameters)	Setting range
Input range ( $\bar{c}n-t$ )	Selects DC voltage/current signal input	0 to 20 mA ( $\bar{0}-20$ )	Displayable from -19999 to 99999 with scaling function. The position of the decimal point can be set as desired.
		4 to 20 mA ( $4-20$ )	
		0 to 5 V ( $\bar{0}-5$ )	
		1 to 5 V ( $1-5$ )	
		±5 V ( $5$ )	
		±10 V ( $10$ )	

**Note:** The initial value for the input range is "4 to 20 mA ( $4-20$ )."

### Scaling

- Analog (Process) Inputs

The K3MA-J converts input signals into desired physical values.

INPUT2: Any input value

DISPLAY2: Displayed value corresponding to INPUT2

INPUT1: Any input value

DISPLAY1: Displayed value corresponding to INPUT1

When DISPLAY1 is set for INPUT1, and DISPLAY2 is set for INPUT2, a line will be displayed joining the two points. (Raise shift, reverse scaling, plus/minus display, etc., can be adjusted as desired.)

Parameter	Setting value	Meaning
$\bar{c}n.1$	-19999 to 99999	Input value for $dSP.1$
$dSP.1$	-19999 to 99999	Display value for $\bar{c}n.1$
$\bar{c}n.2$	-19999 to 99999	Input value for $dSP.2$
$dSP.2$	-19999 to 99999	Display value for $\bar{c}n.2$

Parameter	Setting value	Meaning
$dP$	0.0000	Display four digits after decimal point
	00.000	Display three digits after decimal point
	000.00	Display two digits after decimal point
	0000.0	Display one digit after decimal point
	00000	No decimal point

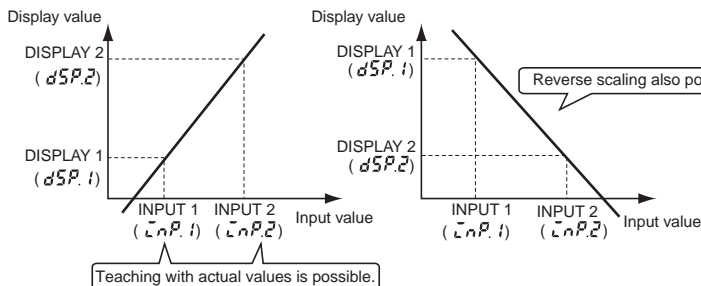

The decimal point can be optionally displayed. When displaying the decimal point, consider the number of digits to follow the decimal point prior to setting the scaling display value.

Reverse scaling, where the display value decreases as the input value increases, is also possible.

Instead of setting by inputting with the  $\uparrow$  Up Key and  $\rightarrow$  Shift Key, current values can be input as scaling input values for teaching. This is useful for making settings while checking the operation status of the K3MA-J.

## Convenient Functions

### Scaling Teach

The parameters ( $\bar{L}nP.1$ ,  $\bar{L}nP.2$ ) for the K3MA-J's initial setting level can be set using actual input values with the teaching function. After displaying the parameters, the actual input settings can be made with the following operation.

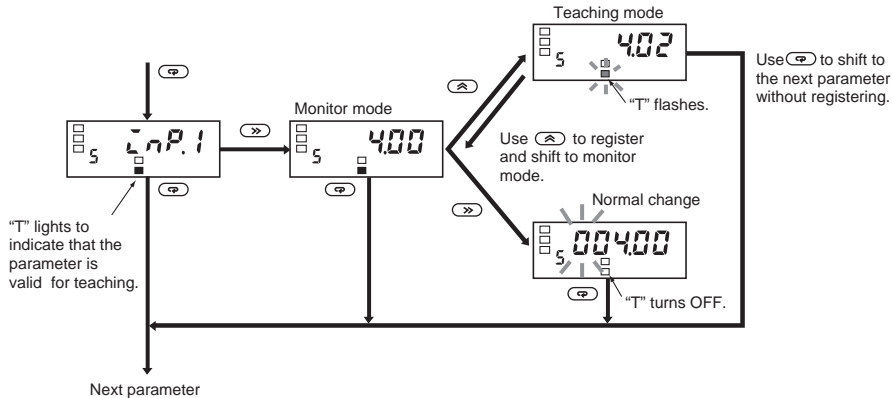

## OUT Types (Comparative Output Models Only)

OUT 1 and OUT 2 can be set to operate in one of the three following modes in accordance with the compared values:

- Upper limit (High Acting):  
The output is turned ON when the measurement value is greater than its set value.
- Lower limit (Low Acting):  
The output is turned ON when the measurement value is less than its set value.
- Upper and lower limits (Outside Band Acting):  
An upper limit (H set value) and lower limit (L set value) can be set independently.  
The output is turned ON when the measurement value is greater than upper-limit set value or less than the lower-limit set value.

### Upper Limit (High Acting)

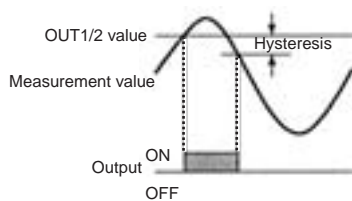

### Lower Limit (Low Acting)

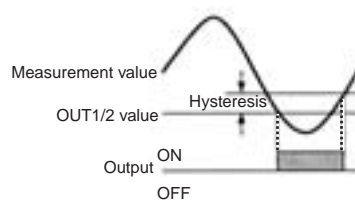

### Upper and Lower Limits (Outside Band Acting)

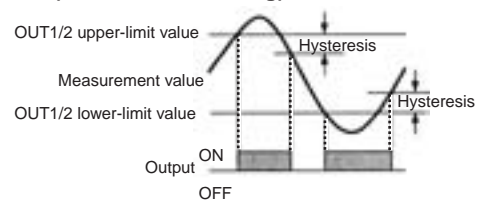

The three types of output operations shown above can be combined as desired. The following are examples of possible combinations.

### Upper Limit 2-stage Output

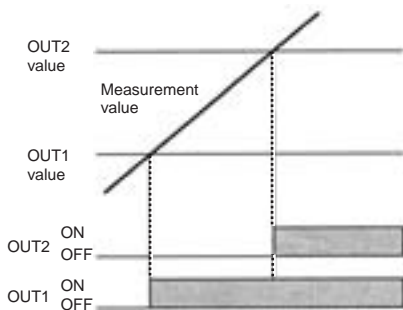

### Threshold Output

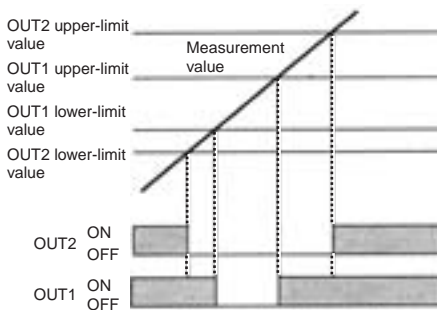

### Combination of Upper Limit and Upper/Lower Limits

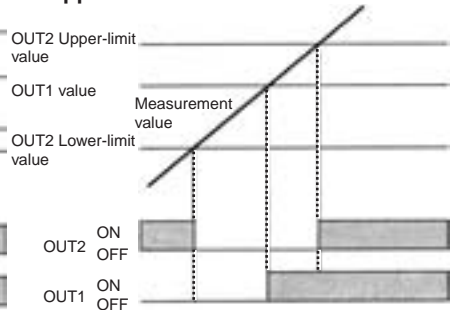

## Parameter Initialization

This function returns all of the parameters to their initial values.

Parameter	Setting value	Meaning
L <sub>INI</sub>	OFF	---
	ON	Initializes all parameters.

Use this to reset the K3MA-J after returning it to its factory-set condition.

## Average Processing

Average processing stabilizes displayed values to minimize flicker by averaging the fluctuating input signals. Average processing can be performed for the measurement values in either of four steps (OFF, 2 times, 4 times, or 8 times).

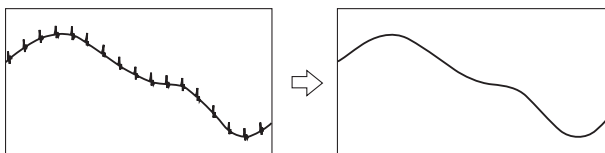

This is useful for ignoring rapid fluctuations, e.g., eliminating spike noise.

## Hysteresis (Comparative Output Models Only)

The hysteresis of comparative outputs can be set to prevent chattering in the output when the measurement value fluctuates finely near the OUT value.

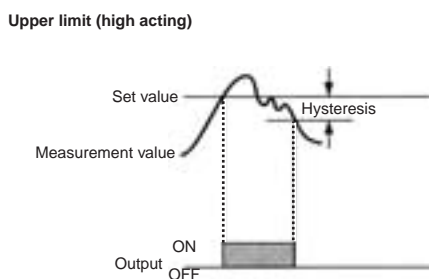

## Zero-limit Function

The zero-limit function changes any value below the set value to zero. This is useful when you want to change negative values to zero rather than display them, or when you want to make the display in the smallest part of the input range zero.

Parameter	Setting value	Meaning
E-L <sub>LN</sub>	OFF	OFF: No zero-limit
	ON	ON: Zero-limit
L <sub>LN-P</sub>	0 to 99	0 to 99: Zero-limit value

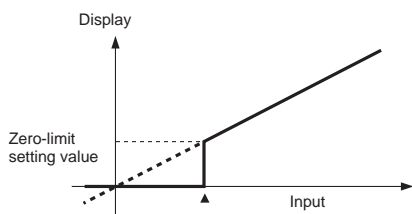

## Changing the Display Color

The color of the value displayed can be set to either red or green. For comparative output models, the display color can be set to change from green to red, or from red to green, according to the status of the comparison criterion.

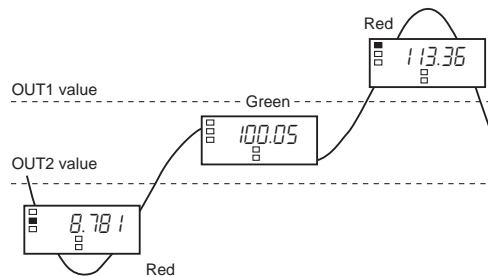

## Display Auto-return Time

This function automatically returns the display to the operation level's current value if no keys are pressed for a preset time (called the display auto-return time).

## Move-to-Protect-Level Time

The time required to shift to the protect level can be set as desired.

## Forced-zero Function

It is possible to shift from a value to the zero point with one touch of the Up Key on the front panel (for example, when adjusting reference values).



**Note:** Used only for releasing the forced-zero with the Protect menu.

## MAX/MIN Display

The maximum and minimum measurement (display) values from the time the power is turned ON until the current time can be stored and displayed. This is useful, for example, when measuring the maximum value.

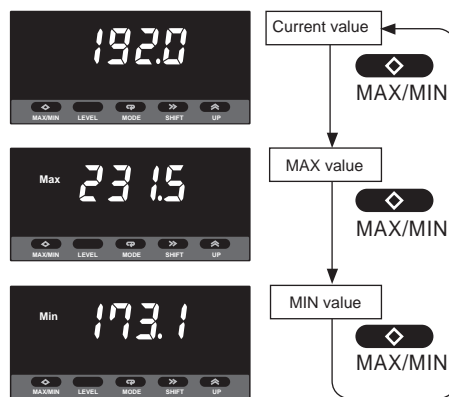

# Nomenclature

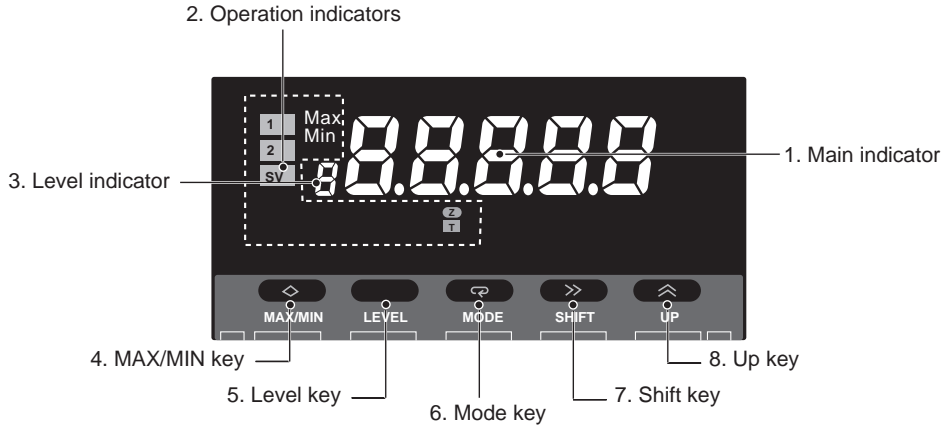

Name	Functions	
1. Main indicator	Displays current values, parameters, and set values.	
2. Operation indicators	1	Lit when output 1 is ON.
	2	Lit when output 2 is ON.
	SV	Lit when a set value is being displayed or changed.
	Max	Lit when the main indicator is showing the MAX value.
	Min	Lit when the main indicator is showing the MIN value.
	Z	Lit during the forced-zero operation.
	T	Lit when the teaching function is operable. Blinks while the teaching function is operating.
3. Level indicator	Displays the current level that the K3MA-J is in. (See below for details.)	
4. MAX/MIN Key	Used to display the MAX and MIN values when a measurement value is being displayed.	
5. Level Key	Used to change the level.	
6. Mode Key	Used to allow the main indicator to indicate parameters sequentially.	
7. Shift Key	Used to enable a set value to be changed. When changing a set value, this key is used to move along the digits.	
8. Up Key	Used to change a set value. Used to set or clear a forced-zero function when a measurement value is being displayed.	

Level indicator	Level
P	Protect
Not lit	Operation
S	Initial setting
F	Advanced-function setting

# Dimensions

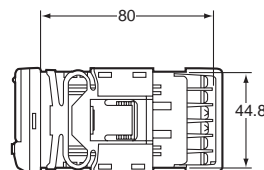
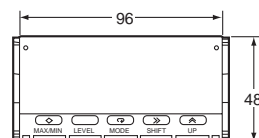
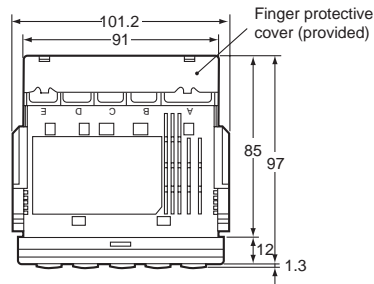
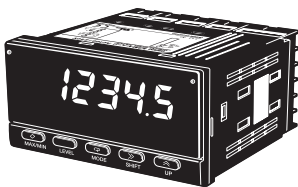

Main indicator character size

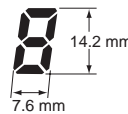

Panel cut-out

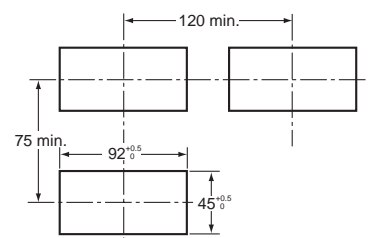

The K3MA-J uses M3 terminals.

# Application Examples

## Monitoring interior tank pressure

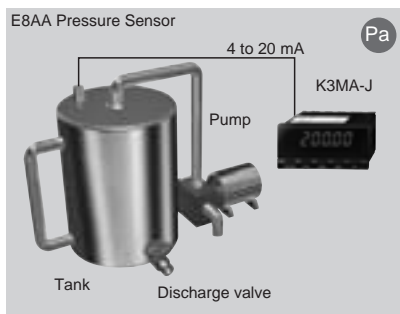

- Monitoring gas pressure
- Inspection instruments in food or pharmaceutical plants

## Displaying/outputting liquid level

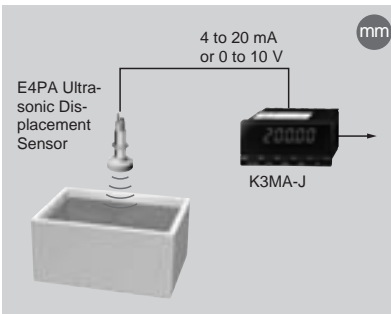

- Monitoring liquid level in cleaning tanks
- Water tanks, devices using chemicals, etc.

## Flowrate sensor

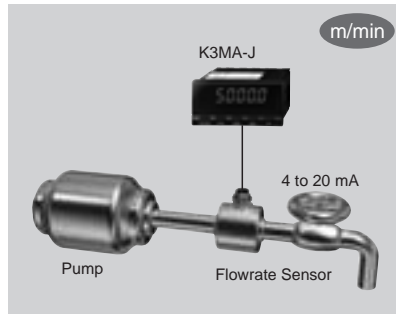

- Monitoring sendout flowrate
- Water processing devices, etc.

# Installation

1. Insert the K3MA-J into the panel cut-out hole.
2. For a waterproof installation, insert the rubber gasket onto the body of the K3MA-J.

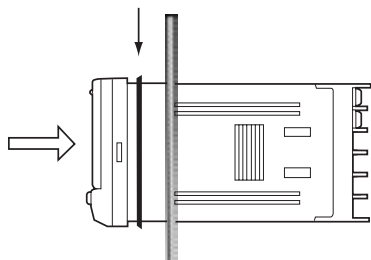

3. Fit the adaptor into the grooves on the left and right sides of the rear case, then push it until it contacts the panel to secure the K3MA-J.

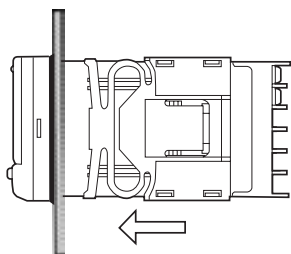

## Wiring Precautions

- Use crimp terminals.
- Tighten the terminal screws to a torque of approximately 0.5 N·m.
- To avoid the influence of noise, route signal lines and power lines separately.

## Wiring

- Use the following M3 crimp terminals.

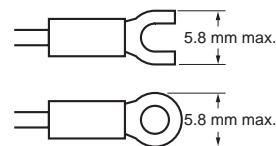

## Unit Labels (Provided)

- The unit labels are not attached to the K3MA-J. Select the desired labels from the provided sheet.

V	A	∇	Δ	%	J	Pa	Ω
s	/	N	m	W	°C	m <sup>3</sup>	k
°F	g	min	mm	rpm			
VA	mV	mA	Hz				
m/min	OMRON						
OUT	OUT						

**Note:** For scales and gauges, use the unit labels that are specified by the relevant laws or regulations.

# Precautions

**WARNING**  
Do not touch any of the terminals while the power is being supplied. Doing so may result in electric shock.

**Caution**  
Do not disassemble the product or touch the internal components of the product while the power is being supplied. Doing so may result in electric shock.

**Caution**  
Do not allow metal objects or wire cuttings to enter the product. Doing so may result in electric shock, fire, or malfunction.

**Caution**  
Perform correct settings for the product according to the control application. Failure to do so may cause unexpected operation, resulting in damage to the product or injury.

**Caution**  
Take safety measures, such as installing a separate monitoring system, to ensure safety even if the product fails. Product failure may prevent comparative outputs from being generated, resulting in serious accidents.

Observe the following precautions to ensure safety.

1. Maintain the power supply voltage within the range specified in the specifications.
2. Maintain the load within the ratings specified in the specifications.
3. Check each terminal for correct number and polarity before connecting it. Incorrect or reverse connections may damage or burn out internal components in the product.
4. Tighten the terminal screws securely. The recommended tightening torque is 0.43 to 0.58 N·m. Loose screws may cause fire or malfunction.
5. Do not connect anything to unused terminals.
6. Provide a switch or circuit breaker so that operators can easily turn OFF the power supply when necessary. Also provide appropriate indications of such devices.
7. Do not attempt to disassemble, repair, or modify the product.
8. Do not use the product where flammable or combustible gases are present.

## Application

### General Precautions

1. Do not use the product in the following locations:
  - Locations subject to direct radiant heat from heating equipment.
  - Locations subject to exposure to water, oil, or chemicals.
  - Locations subject to direct sunlight.
  - Locations subject to dust or corrosive gases (particularly sulfuric gas or ammonia gas).
  - Locations subject to severe changes in temperature.
  - Locations subject to icing or condensation.
  - Locations subject to shock or vibration.
2. Do not block heat dissipation around the product, i.e., provide sufficient space for heat dissipation.
3. Ensure that the rated voltage is reached within two seconds after the power is turned ON.
4. Conduct aging for 15 minutes min. after power is turned ON for correct measurement.

5. Do not touch the slit sections or terminals while the power is being supplied to prevent the product from being affected by static electricity.
6. Do not lay heavy objects on the product during use or storage. Doing so may deform or deteriorate the product.
7. Do not use paint thinner for cleaning. Use commercially available alcohol.

### Mounting

- Mount the product to a panel that is 1 to 8 mm thick.
- Install the product in a horizontal position.
- Use crimp terminals that match screw sizes.

### Noise Prevention

- Install the product as far as possible from devices that generate strong, high-frequency fields (such as high-frequency welders or sewing machines) or surges.
- Install surge absorbers or noise filters on nearby devices that generate noise (particularly, motors, transformers, solenoids, magnet coils, and other devices that have a high inductance component).

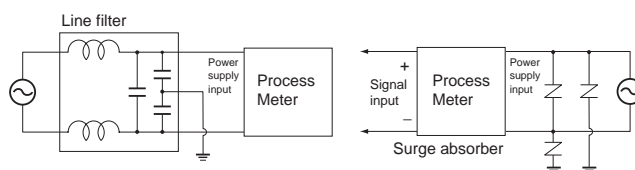

- To prevent inductive noise, separate the terminal block wiring for the product from high-voltage or high-current power lines. Do not route the wiring for the product in parallel with or tie it in a bundle with power lines. Take the following countermeasures against inductive noise in input lines.

### Analog Signal Inputs

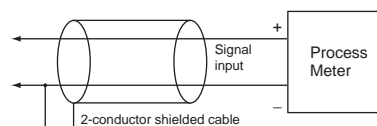

- When using a noise filter for the power supply, check for the voltage and current and install it as close as possible to the Process Meter.
- Do not install the product near radios, television sets, or wireless devices. Doing so may cause reception interference.

### Increasing Service Life

- Do not use the product in locations where the temperature or humidity exceeds the ratings or where condensation may occur. When installing the product in a panel, be sure that the temperature around the product (not the temperature around the panel) does not exceed the ratings. The product service life depends on the ambient temperature. The higher the ambient temperature, the shorter the service life. To extend the product service life, lower the temperature inside the Process Meter.
- Use and store the product within the temperature and humidity ranges given in the specifications. When gang-mounting Process Meters or arranging them vertically, heat generated by the Process Meters will cause the internal temperature to rise, reducing the service life. In such cases, consider forced cooling methods, such as using a fan to circulate air around the Process Meters. Do not, however, allow only the terminals to be cooled. Doing so will increase measurement error.
- The life of the output relays is greatly affected by the switching capacity and switching conditions. Use these relays within their rated load and electrical life. The contacts may fuse or burn if they are used past their electrical life.

# Operating Procedures

## ■ Levels

“Level” refers to a grouping of parameters. The following table lists the operations that are possible in each of the levels, and the diagram tells how to move between levels. There are some parameters that are not displayed for certain models.

Level name	Function	Measurement
Protect	Setting lockouts.	Continue
Operation	Displaying current values, setting/clearing forced-zero function, and setting OUT 1/2 values.	Continue
Initial setting	Making initial settings of input type, scaling, output operating action, and other parameters.	Stopped
Advanced-function setting	Setting average processing, display color settings, and other advanced-function parameters.	Stopped

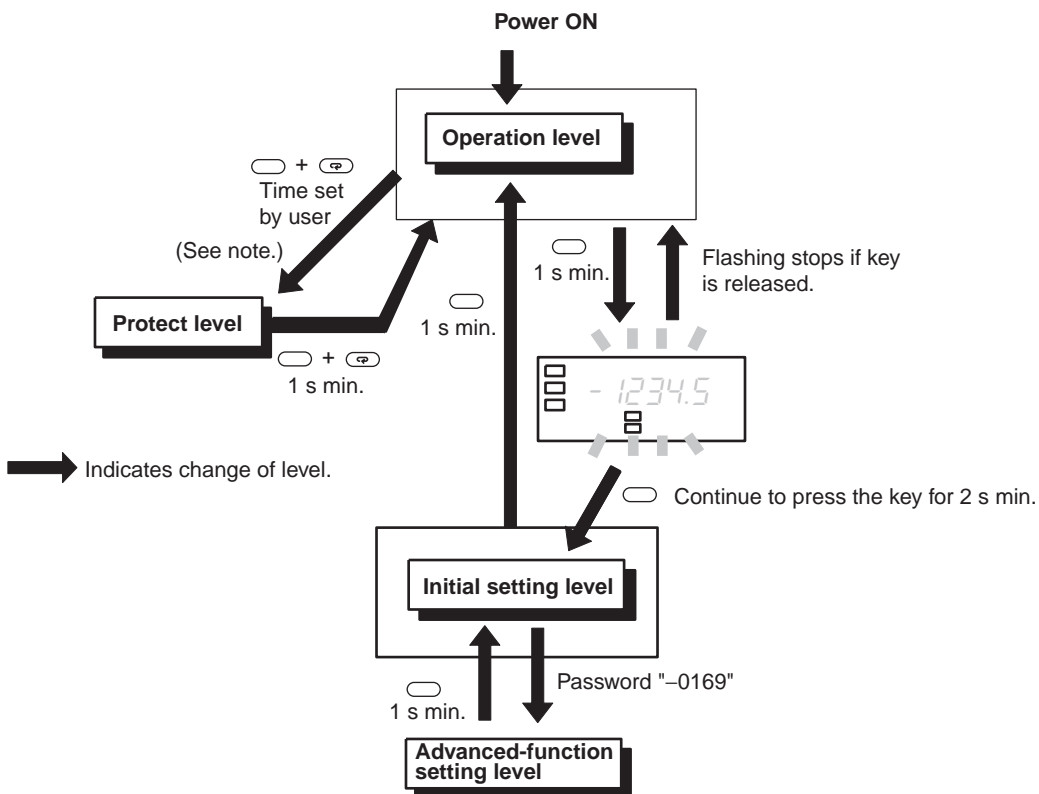

**Note:** The move-to-protect-level time can be set in the advanced-function setting level.

## Parameters

- Note:**
1. Some parameters are not displayed for certain models.
  2. The K3MA-J will stop measurement if the level is changed to the initial setting level or the advanced-function setting level.
  3. If the input range is changed, some parameters are set to default values. Therefore, set the input range first.
  4. Settings displayed in reversed colors are defaults.

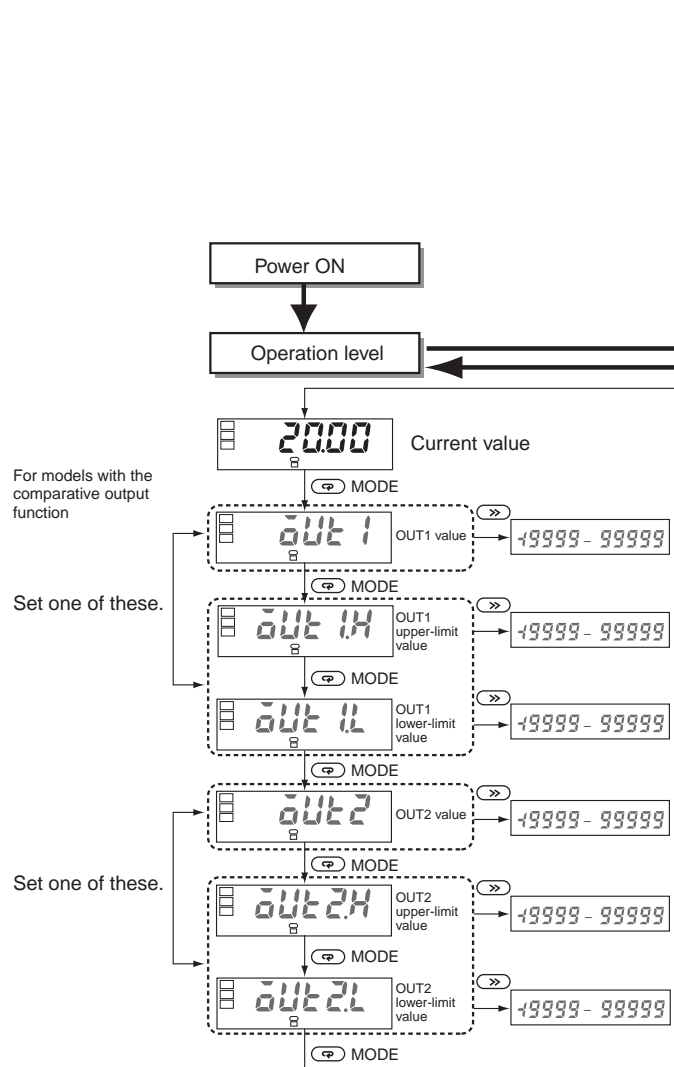





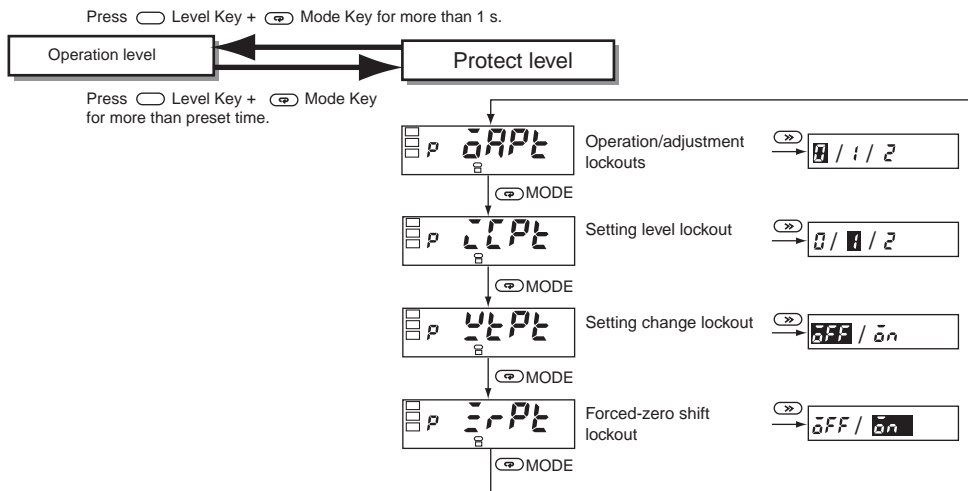

## Operation/Adjustment Lockouts

Restricts key operations for operation level and adjustment level.

Parameter	Setting	Operation level	
		Current value display	Set value display
0APL	0	Allowed	Allowed
	1	Allowed	Allowed
	2	Allowed	Prohibited

- Initial setting is 0.
- This cannot be displayed on models not equipped with the comparative output function.

## Setting Level Lockout

Restricts shifting to initial setting level or advanced-function setting level.

Parameter	Setting	Shift to initial setting level	Shift to advanced-function setting level
		LCP	0
1	Allowed		Prohibited
2	Prohibited		Prohibited

## Setting Change Lockout

Restricts setting changes by key operation. When this lockout is set, it is no longer possible to shift to a setting change mode.

Parameter	Setting	Setting change by key operation
LPL	OFF	Allowed
	ON	Prohibited

However, all protect level parameters can still be changed.

## Forced-zero Lockout

Restricts the setting or release of a forced-zero by front-panel key operation.

Parameter	Setting	Setting/release of forced-zero by key operation
ZPL	OFF	Allowed
	ON	Prohibited

## Initial Settings

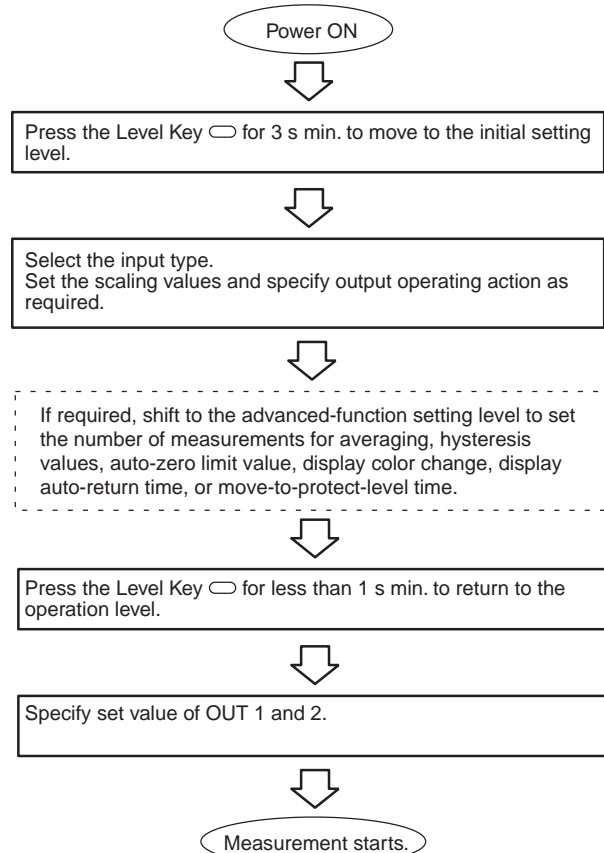

## Setting Example

### Initial Settings

The settings for the following example are shown here.

#### Example: Tank pressure display

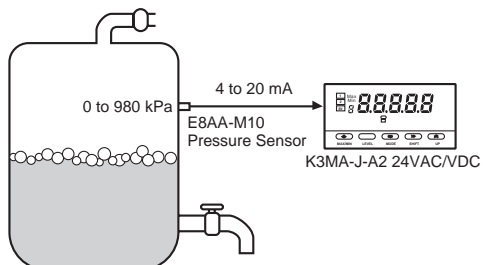

Here, the pressure inside the tank is to be displayed in units of 0.1 kPa.

- Pressure Sensor: E8AA-M10  
Measuring range: 0 to 980 kPa, output 4 to 20 mA

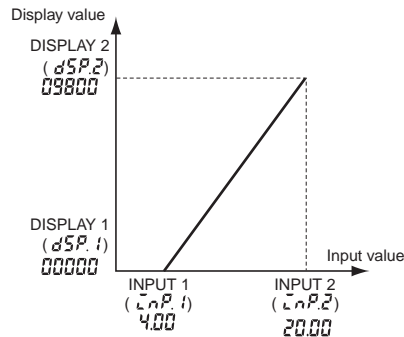

- Set the K3MA-J input type to the 4 to 20 mA input range.  
Parameter:  $\overline{IN-T}$  (input type), Setting value: 4-20
- Set the display values for the corresponding input values.  
Set the scaling as shown below for the following correspondence:  
input 4 mA-->display 0.0, input 20 mA-->display 980.0

Parameter	Setting value
$\overline{IN.P.1}$ (scaling input value 1)	4.00
$dSP.1$ (scaling display value 1)	00000
$\overline{IN.P.2}$ (scaling input value 2)	20.00
$dSP.2$ (scaling display value 2)	09800
$dP$ (decimal point position)	0000.0

**Note:** The decimal point position here refers to the position in the number after scaling. When setting the scaling display value, it is necessary to consider the number of digits to be displayed past the decimal point.

## Troubleshooting

When an error occurs, error details will be displayed on the main indicator. Confirm the error from the main indicator and take the appropriate countermeasures.

Level display	Main indicator	Error contents	Countermeasures
Not lit	<i>E IIII</i>	RAM memory error	Repair is necessary. Consult your OMRON sales representative.
5	<i>E IIII</i>	EEPROM memory error	When this error is displayed, press the Level Key for 3 seconds, and the settings will be restored to the factory settings. If the error cannot be recovered, repair is necessary. Consult your OMRON sales representative.
Not lit	Flashes <i>5.Err</i>	You will see this indication when turning ON the product the first time after purchase. This is because the input signal value is 0 mA at that time even though the range is factory set to 4 to 20 mA. Input error	At the initial setting level, set the input type and other parameters according to your application. Promptly change the input voltage/current to a value that falls within the measurement range. If the error cannot be recovered, repair is necessary. Consult your OMRON sales representative.
Not lit	Flashes <i>99999</i>	The scaling display value exceeds 99999.	Promptly change the input to a value that falls within the specified range. The scaling value may be inappropriate. Review the scaling value at the initial setting level.
Not lit	Flashes <i>-19999</i>	The scaling display value is lower than -19999.	Promptly change the input to a value that falls within the specified range. The scaling value may be inappropriate. Review the scaling value at the initial setting level.

# Warranty and Limitations of Liability

---

## ■ WARRANTY

OMRON's exclusive warranty is that the products are free from defects in materials and workmanship for a period of one year (or other period if specified) from date of sale by OMRON.

OMRON MAKES NO WARRANTY OR REPRESENTATION, EXPRESS OR IMPLIED, REGARDING NON-INFRINGEMENT, MERCHANTABILITY, OR FITNESS FOR PARTICULAR PURPOSE OF THE PRODUCTS. ANY BUYER OR USER ACKNOWLEDGES THAT THE BUYER OR USER ALONE HAS DETERMINED THAT THE PRODUCTS WILL SUITABLY MEET THE REQUIREMENTS OF THEIR INTENDED USE. OMRON DISCLAIMS ALL OTHER WARRANTIES, EXPRESS OR IMPLIED.

## ■ LIMITATIONS OF LIABILITY

OMRON SHALL NOT BE RESPONSIBLE FOR SPECIAL, INDIRECT, OR CONSEQUENTIAL DAMAGES, LOSS OF PROFITS, OR COMMERCIAL LOSS IN ANY WAY CONNECTED WITH THE PRODUCTS, WHETHER SUCH CLAIM IS BASED ON CONTRACT, WARRANTY, NEGLIGENCE, OR STRICT LIABILITY.

In no event shall the responsibility of OMRON for any act exceed the individual price of the product on which liability is asserted.

IN NO EVENT SHALL OMRON BE RESPONSIBLE FOR WARRANTY, REPAIR, OR OTHER CLAIMS REGARDING THE PRODUCTS UNLESS OMRON'S ANALYSIS CONFIRMS THAT THE PRODUCTS WERE PROPERLY HANDLED, STORED, INSTALLED, AND MAINTAINED AND NOT SUBJECT TO CONTAMINATION, ABUSE, MISUSE, OR INAPPROPRIATE MODIFICATION OR REPAIR.

# Application Considerations

---

## ■ SUITABILITY FOR USE

OMRON shall not be responsible for conformity with any standards, codes, or regulations that apply to the combination of products in the customer's application or use of the products.

At the customer's request, OMRON will provide applicable third party certification documents identifying ratings and limitations of use that apply to the products. This information by itself is not sufficient for a complete determination of the suitability of the products in combination with the end product, machine, system, or other application or use.

The following are some examples of applications for which particular attention must be given. This is not intended to be an exhaustive list of all possible uses of the products, nor is it intended to imply that the uses listed may be suitable for the products.

- Outdoor use, uses involving potential chemical contamination or electrical interference, or conditions or uses not described in this catalog.
- Nuclear energy control systems, combustion systems, railroad systems, aviation systems, medical equipment, amusement machines, vehicles, safety equipment, and installations subject to separate industry or government regulations.
- Systems, machines, and equipment that could present a risk to life or property.

Please know and observe all prohibitions of use applicable to the products.

NEVER USE THE PRODUCTS FOR AN APPLICATION INVOLVING SERIOUS RISK TO LIFE OR PROPERTY WITHOUT ENSURING THAT THE SYSTEM AS A WHOLE HAS BEEN DESIGNED TO ADDRESS THE RISKS, AND THAT THE OMRON PRODUCTS ARE PROPERLY RATED AND INSTALLED FOR THE INTENDED USE WITHIN THE OVERALL EQUIPMENT OR SYSTEM.

**ALL DIMENSIONS SHOWN ARE IN MILLIMETERS.**

To convert millimeters into inches, multiply by 0.03937. To convert grams into ounces, multiply by 0.03527.

Cat. No. N108-E1-04A **In the interest of product improvement, specifications are subject to change without notice.**

## OMRON Corporation

Industrial Automation Company

Industrial Devices and Components Division H.Q.

Measuring Components Department

Shiokoji Horikawa, Shimogyo-ku,

Kyoto, 600-8530 Japan

Tel: (81)75-344-7080/Fax: (81)75-344-7189

Printed in Japan

0903-0.4M (1001) (B)

# Temperature Meter K3MA-L

## Highly Visible LCD Display with 2-color (Red and Green) LEDs

- Wide input range - select from two types of platinum-resistance thermometers and ten types of thermocouples.
- Front-panel key operation for easy setting.
- Average processing function suppresses flicker.
- Temperature input shift and temperature unit selection functions.
- Easy confirmation of max/min display.
- Short 80-mm depth (measured from edge of face plate).
- Finger protective cover (standard equipment) protects against electric shock.
- Water- and dust-proof NEMA4X (IP66 equivalent) front panel.
- Recognized to conform to U.S. and Canadian requirements under the Component Recognition Program of UL.
- CE marking.



## Model Number Structure

### Model Number Legend

K3MA-L- -   
1 2 3

**1. Input Type**

L: Platinum-resistance thermometer or thermocouple

**2. Output Type**

None: No output

C: With relay contact output (SPDT)

**3. Supply Voltage**

100-240VAC: 100 to 240 VAC

24VAC/VDC: 24 VAC/VDC

## Ordering Information

### List of Models

Input type	Supply voltage	Output	Model
Platinum-resistance thermometer or thermocouple	100 to 240 VAC	None	K3MA-L 100-240VAC
		1 relay contact output (SPDT)	K3MA-L-C 100-240VAC
	24 VAC/VDC	None	K3MA-L 24VAC/VDC
		1 relay contact output (SPDT)	K3MA-L-C 24VAC/VDC

### Accessories (Order Separately)

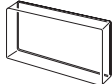
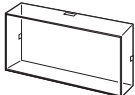
Name	Shape	Model
Splash-proof Soft Cover		K32-49SC
Hard Cover		K32-49HC



## ■ Characteristics

Indication accuracy (at 23±5°C) (See note.)	Thermocouple: (±0.5% of indication value or ±1°C, whichever greater) ±1 digit max. Platinum-resistance thermometer: (±0.5% of indication value or ±1°C, whichever greater) ±1 digit max.
Input	Thermocouple: K, J, T, E, L, U, N, R, S, B Platinum-resistance thermometer: JPt100, Pt100
Measurement method	Double integral method
Sampling period	500 ms
Display refresh period	Sampling period (sampling times multiplied by number of averaging times if average processing is selected.)
Max. displayed digits	4 digits (–1999 to 9999)
Display	7-segment digital display, Character height: 14.2 mm
Polarity display	“–” is displayed automatically with a negative input signal.
Zero display	Leading zeros are not displayed.
Input shift	Input shift equivalent to the setting value supported for all points within the sensor measurement range.
Hold function	Max hold (maximum value), Min hold (minimum value)
Hysteresis setting	Programmable with front-panel key inputs (0001 to 9999).
Other functions	Display color change (green (red), green, red (green), red) Average processing (simple average OFF/2/4/8 operations) Setting change lockout Parameter initialization
Output	Relay contact (SPDT)
Delay in comparative outputs	1 s max.
Degree of protection	Front panel: NEMA4X for indoor use (equivalent to IP66) Rear case: IEC standard IP20 Terminals: IEC standard IP00 + finger protection (VDE0106/100)
Memory protection	Non-volatile memory (EEPROM) (possible to rewrite 100,000 times)

**Note:** The indication accuracy of the K thermocouple at a temperature of –200 to 1300°C is ±2°C ±1 digit maximum.  
The indication accuracy of the T and N thermocouples at a temperature of –100°C or less is ±2°C ±1 digit maximum.  
The indicator accuracy of the U and L thermocouples at any temperature is ±2°C ±1 digit maximum.  
The indication accuracy of the B thermocouple at a temperature of 400°C or less is unrestricted.  
The indication accuracy of the R and S thermocouples at a temperature of 200°C or less is ±3°C ±1 digit maximum.

## ■ Measuring Ranges

### Platinum-resistance Thermometer

Input		Pt100			JPt100	
Range	°C	–200 to 850	–199.9 to 500.0	0.0 to 100.0	–199.9 to 500.0	0.0 to 100.0
	°F	–300 to 1500	–199.9 to 900.0	0.0 to 210.0	–199.9 to 900.0	0.0 to 210.0
Parameter		0	1	2	3	4

### Thermocouple

Input		K		J	T		E	L	U		N	R	S	B	
Range	°C	–200 to 1300	–20.0 to 500.0	–100 to 850	–20.0 to 400.0	–200 to 400	–199.9 to 400.0	0 to 600	–100 to 850	–200 to 400	–199.9 to 400.0	–200 to 1300	0 to 1700	0 to 1700	100 to 1800
	°F	–300 to 2300	0.0 to 900.0	–100 to 1500	0.0 to 750	–300 to 700	–199.9 to 700.0	0 to 1100	–100 to 1500	–300 to 700	–199.9 to 700.0	–300 to 2300	0 to 3000	0 to 3000	300 to 3200
Parameter		5	6	7	8	9	10	11	12	13	14	15	16	17	18

## ■ Input/Output Ratings

### Relay Contact Output

Item	Resistive load (cosφ = 1)	Inductive load (cosφ = 0.4, L/R = 7 ms)
Rated load (UL ratings)	5 A at 250 VAC, 5 A at 30 VDC	1.5 A at 250 VAC, 1.5 A at 30 VDC
Rated carry current	5 A max. (at COM terminal)	
Max. contact voltage	400 VAC, 150 VDC	
Max. contact current	5 A (at COM terminal)	
Max. switching capacity	2,000 VA, 192 W	375 VA, 30 W
Min. permissible load (P level, reference value)	10 mA at 5 VDC	
Mechanical life	20,000,000 times min. (at a switching frequency of 1,200 time/min)	
Electrical life (at an ambient temperature of 20°C)	100,000 times min. (at a rated load switching frequency of 10 time/min)	

# Connections

## Terminal Arrangement

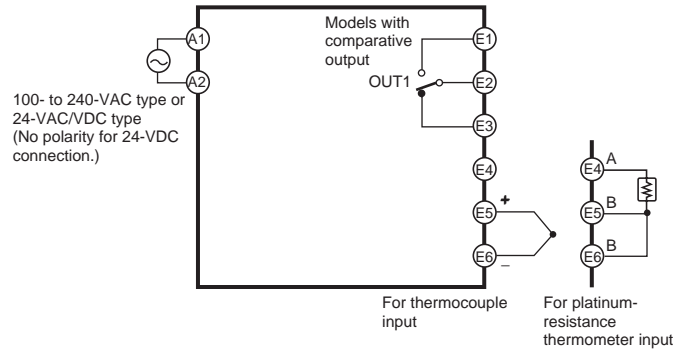
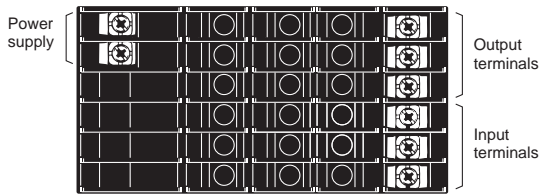

Terminal No.	Name	Description
A1 - A2	Operation power	Connects the operation power supply.
E4 - E6 - E5	Thermocouple or platinum-resistance thermometer input	Connects the thermocouple or platinum-resistance thermometer input.
E1 - E2 - E3	Outputs	Outputs the relay outputs.

## Block Diagram

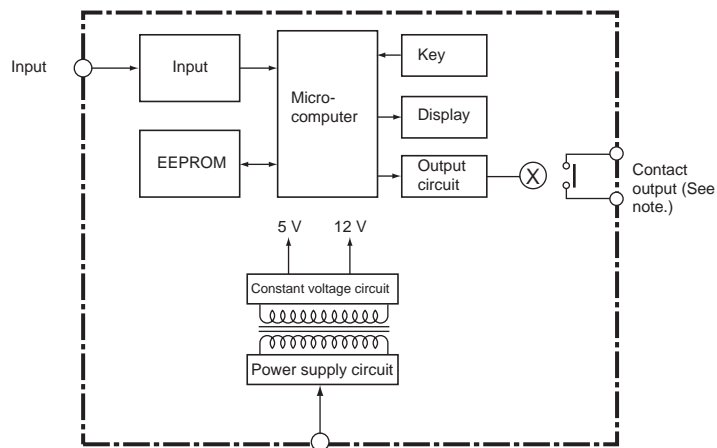

Note: Relay output models only.



# Operation

## ■ Main Functions

### Input Types and Ranges

Parameter	Setting	Input type	Meaning		
c-n-t	0	Platinum-resistance thermometer	Pt100	-200 to 850°C	-300 to 1500°F
	1			-199.9 to 500.0°C	-199.9 to 900.0°F
	2			0.0 to 100.0°C	0.0 to 210.0°F
	3			-199.9 to 500.0°C	-199.9 to 900.0°F
	4	0.0 to 100.0°C	0.0 to 210.0°F		
	5	Thermocouple	K	-200 to 1300°C	-300 to 2300°F
	6			-20.0 to 500.0°C	0.0 to 900.0°F
	7		J	-100 to 850°C	-100 to 1500°F
	8			-20.0 to 400.0°C	0.0 to 750.0°F
	9		T	-200 to 400°C	-300 to 700°F
	10			-199.9 to 400.0°C	-199.9 to 700.0°F
	11		E	0 to 600°C	0 to 1100°F
	12			-100 to 850°C	-100 to 1500°F
	13		U	-200 to 400°C	-300 to 700°F
	14			-199.9 to 400.0°C	-199.9 to 700.0°F
	15		N	-200 to 1300°C	-300 to 2300°F
	16			0 to 1700°C	0 to 3000°F
	17		R	0 to 1700°C	0 to 3000°F
18	100 to 1800°C			300 to 3200°F	

**Note:** The initial value is "5: thermocouple K (-200 to 1300°C/-300 to 2300°F)."

### Temperature Unit Selection

Either centigrade (°C) or fahrenheit (°F) can be selected as the temperature unit.

Parameter	Setting	Meaning
d-U	C	Display in °C.
	F	Display in °F.

- Lower limit (Low Acting):  
The output is turned ON when the measurement value is less than its set value.
- Upper and lower limits (Outside Band Acting):  
An upper limit (H set value) and lower limit (L set value) can be set independently.  
The output is turned ON when the measurement value is greater than the upper-limit set value or less than the lower-limit set value.

### OUT Types (Comparative Output Models Only)

OUT 1 can be set to operate in one of the three following modes in accordance with the compared values:

- Upper limit (High Acting):  
The output is turned ON when the measurement value is greater than its set value.

Parameter	Setting	Meaning
oUt 1.t	H $\bar{c}$	Upper limit: Alarm operates at upper limit.
	L $\bar{o}$	Lower limit: Alarm operates at lower limit.
	H $\bar{c}$ -L $\bar{o}$	Upper and lower limits: Alarm operates at upper and lower limits.

#### Upper Limit (High Acting)

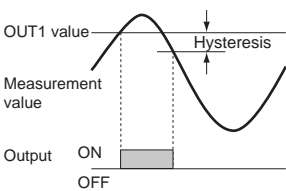

#### Lower Limit (Low Acting)

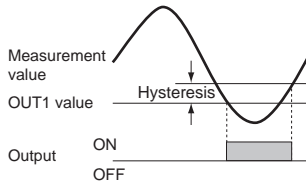

#### Upper and Lower Limits (Outside Band Acting)

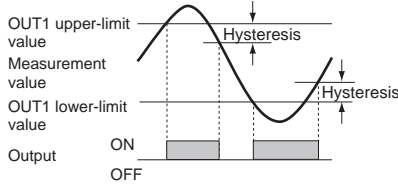

## Temperature Input Shift

Input shift equivalent to the setting value supported for all points within the sensor measurement range.

Parameter	Setting
$\bar{c}n5$	- 1999 to 9999

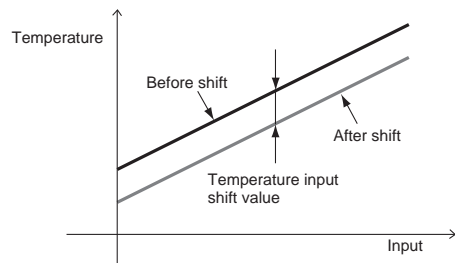

## Parameter Initialization

This function returns all of the parameters to their initial values.

Parameter	Setting	Meaning
$\bar{c}n\bar{c}t$	$\bar{o}ff$	---
	$\bar{o}n$	Initializes all parameters.

Use this to reset the K3MA-L after returning it to its factory-set condition.

## Average Processing

Average processing stabilizes displayed values to minimize flicker by averaging the fluctuating input signals. Average processing can be performed for the measurement values in either of four steps (OFF, 2 times, 4 times, or 8 times).

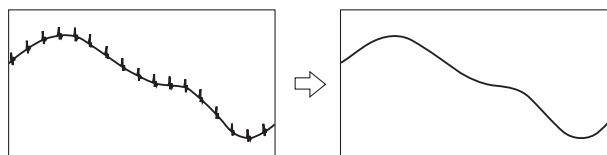

This is useful for ignoring rapid fluctuations, e.g., eliminating spike noise.

## Hysteresis (Comparative Output Models Only)

The hysteresis of comparative outputs can be set to prevent chattering in the output when the measurement value fluctuates finely near the OUT value.

### Upper limit (high acting)

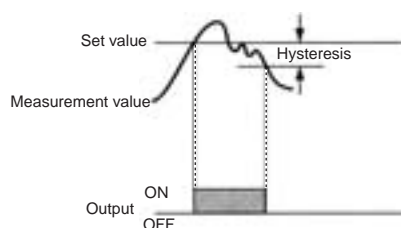

## Changing the Display Color

The color of the value displayed can be set to either red or green. For comparative output models, the display color can be set to change from green to red, or from red to green, according to the status of the comparison criterion.

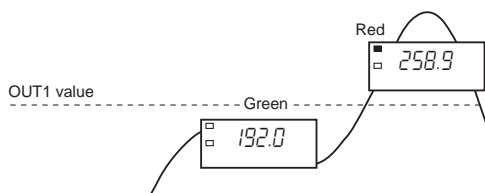

## Display Auto-return Time

This function automatically returns the display to the operation level's current value if no keys are pressed for a preset time (called the display auto-return time).

## Move-to-Protect-Level Time

The time required to shift to the protect level can be set as desired.

## MAX/MIN Display

The maximum and minimum measurement (display) values from the time the power is turned ON until the current time can be stored and displayed. This is useful, for example, when measuring the maximum value.

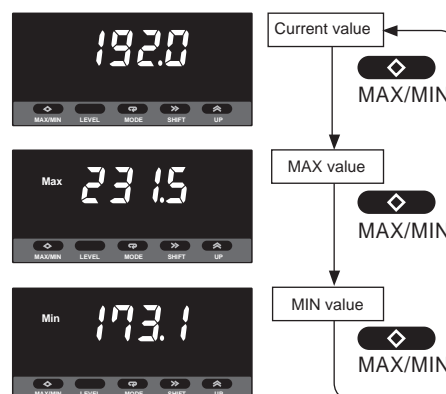

# Nomenclature

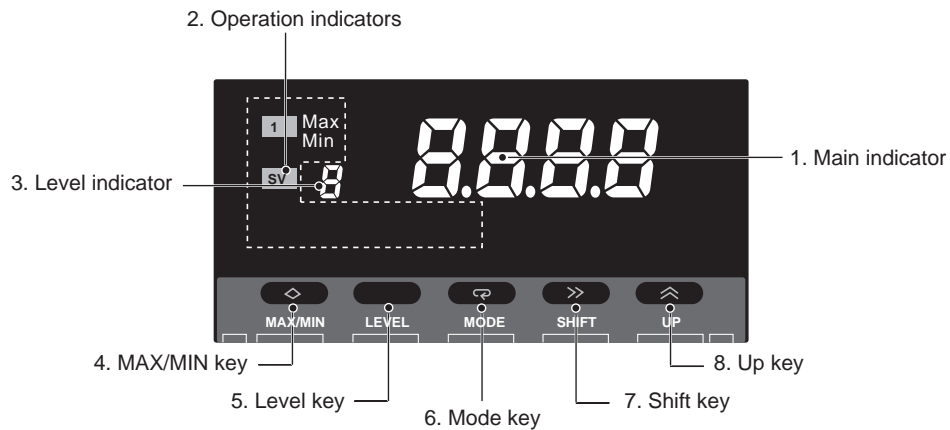

Name		Functions
1. Main indicator		Displays current values, parameters, and set values.
2. Operation indicators	1	Lit when output 1 is ON.
	SV	Lit when a set value is being displayed or changed.
	Max	Lit when the main indicator is showing the MAX value.
	Min	Lit when the main indicator is showing the MIN value.
3. Level indicator		Displays the current level that the K3MA-L is in. (See below for details.)
4. MAX/MIN Key		Used to display the MAX and MIN values when a measurement value is being displayed.
5. Level Key		Used to change the level.
6. Mode Key		Used to allow the main indicator to indicate parameters sequentially.
7. Shift Key		Used to enable a set value to be changed. When changing a set value, this key is used to move along the digits.
8. Up Key		Used to change a set value. Used to set or clear a forced-zero function when a measurement value is being displayed.

Level indicator	Level
$\bar{P}$	Protect
Not lit	Operation
$\bar{A}$	Adjustment
$\bar{S}$	Initial setting
$\bar{F}$	Advanced-function setting

## Dimensions

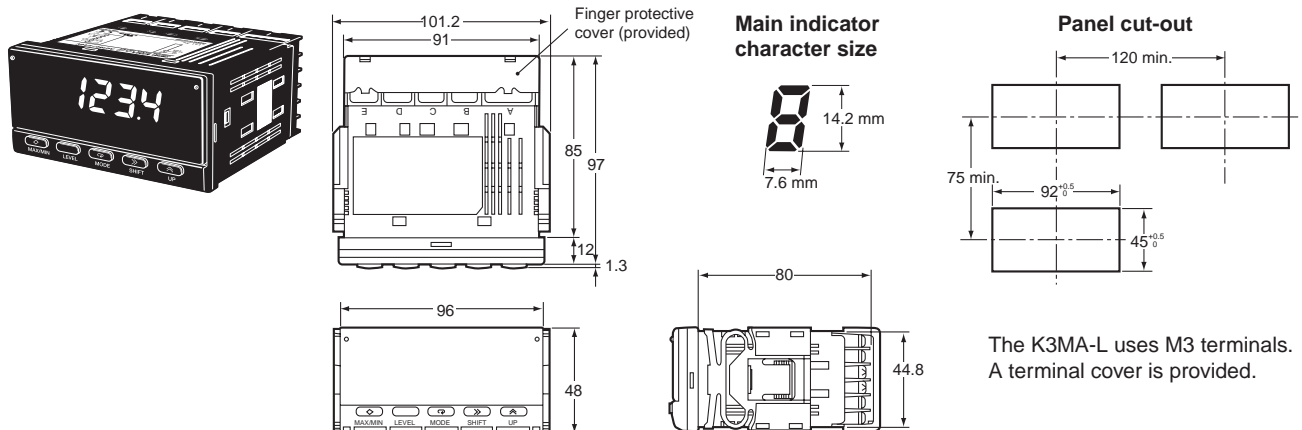

## Application Examples

### Monitoring the temperature of an industrial furnace

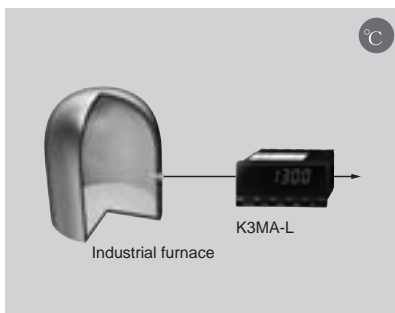

- Monitoring the temperature of an industrial furnace/sintering furnace.
- Monitoring/alarm function for disinfecting equipment.

### Sending a temperature alarm for molding equipment

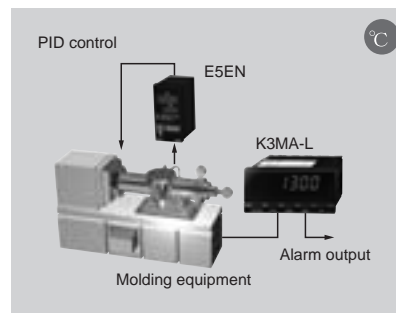

- Monitoring (failsafe checking) abnormal temperatures in molding equipment.
- Monitoring the liquid temperature for cleaning devices.

### Monitoring the bearing temperature for a generator motor

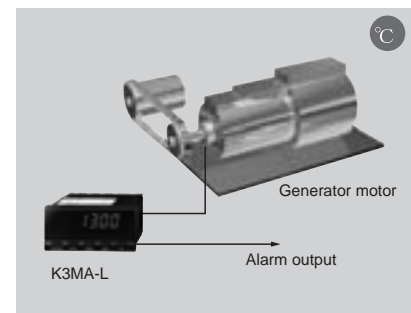

- Monitoring temperature rises in electric power generating facilities.
- Inspecting temperatures in machines and devices.

# Installation

1. Insert the K3MA-L into the panel cut-out hole.
2. For a waterproof installation, insert the rubber gasket onto the body of the K3MA-L.

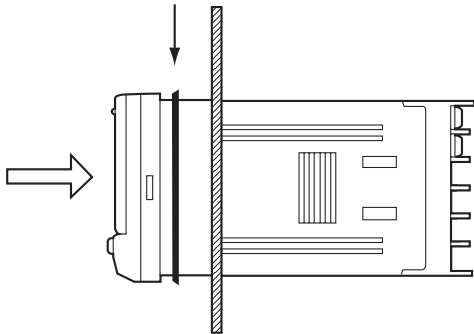

3. Fit the adaptor into the grooves on the left and right sides of the rear case, then push it until it contacts the panel to secure the K3MA-L.

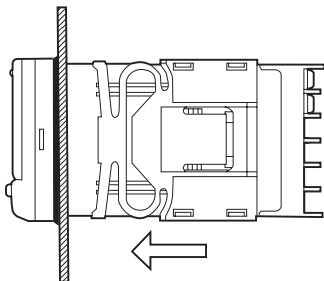

## ■ Wiring Precautions

- Use crimp terminals.
- Tighten the terminal screws to a torque of approximately 0.5 N·m.
- To avoid the influence of noise, route signal lines and power lines separately.

## ■ Wiring

- Use the following M3 crimp terminals.

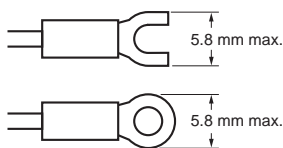

## ■ Unit Labels (Provided)

- The unit labels are not attached to the K3MA-L. Select the desired labels from the provided sheet.

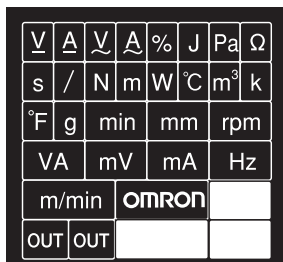

**Note:** For scales and gauges, use the unit labels that are specified by the relevant laws or regulations.

# Precautions

## ⚠ WARNING

Do not touch any of the terminals while the power is being supplied. Doing so may result in electric shock.

## ⚠ Caution

Do not disassemble the product or touch the internal components of the product while the power is being supplied. Doing so may result in electric shock.

## ⚠ Caution

Do not allow metal objects or wire cuttings to enter the product. Doing so may result in electric shock, fire, or malfunction.

## ⚠ Caution

Perform correct settings for the product according to the control application. Failure to do so may cause unexpected operation, resulting in damage to the product or injury.

## ⚠ Caution

Take safety measures, such as installing a separate monitoring system, to ensure safety even if the product fails. Product failure may prevent comparative outputs from being generated, resulting in serious accidents.

Observe the following precautions to ensure safety.

1. Maintain the power supply voltage within the range specified in the specifications.
2. Maintain the load within the ratings specified in the specifications.
3. Check each terminal for correct number and polarity before connecting it. Incorrect or reverse connections may damage or burn out internal components in the product.
4. Tighten the terminal screws securely. The recommended tightening torque is 0.43 to 0.58 N·m. Loose screws may cause fire or malfunction.
5. Do not connect anything to unused terminals.
6. Provide a switch or circuit breaker so that operators can easily turn OFF the power supply when necessary. Also provide appropriate indications of such devices.
7. Do not attempt to disassemble, repair, or modify the product.
8. Do not use the product where flammable or combustible gases are present.

## Application

### General Precautions

1. Do not use the product in the following locations:
  - Locations subject to direct radiant heat from heating equipment.
  - Locations subject to exposure to water, oil, or chemicals.
  - Locations subject to direct sunlight.
  - Locations subject to dust or corrosive gases (particularly, sulfuric gas or ammonia gas).
  - Locations subject to severe changes in temperature.
  - Locations subject to icing or condensation.
  - Locations subject to shock or vibration.
2. Do not block heat dissipation around the product, i.e., provide sufficient space for heat dissipation.
3. Ensure that the rated voltage is reached within two seconds after the power is turned ON.
4. Conduct aging for 15 minutes min. after power is turned ON for correct measurement.

5. Do not touch the slit sections or terminals while the power is being supplied to prevent the product from being affected by static electricity.
6. Do not lay heavy objects on the product during use or storage. Doing so may deform or deteriorate the product.
7. Do not use paint thinner for cleaning. Use commercially available alcohol.

### Mounting

- Mount the product to a panel that is 1 to 8 mm thick.
- Install the product in a horizontal position.
- Use crimp terminals that match screw sizes.

### Noise Prevention

- Install the product as far as possible from devices that generate strong, high-frequency fields (such as high-frequency welders or sewing machines) or surges.
- Install surge absorbers or noise filters on nearby devices that generate noise (particularly motors, transformers, solenoids, magnet coils, and other devices that have a high inductance component). Do not connect a surge absorber to the temperature sensor input section of the K3MA-L.

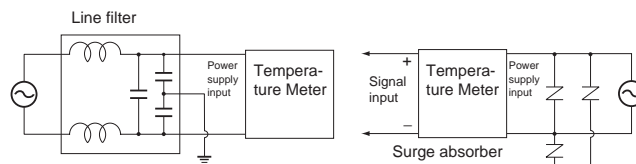

- To prevent inductive noise, separate the terminal block wiring for the product from high-voltage or high-current power lines. Do not route the wiring for the product in parallel with or tie it in a bundle with power lines. Take the following countermeasures against inductive noise in input lines.

#### Temperature Inputs

Separate the lead wire that connects the product with a temperature sensor from the load line to prevent the product from being affected by inductive noise.

- When using a noise filter for the power supply, check for the voltage and current and install it as close as possible to the Temperature Meter.
- Do not install the product near radios, television sets, or wireless devices. Doing so may cause reception interference.

### Increasing Service Life

- Do not use the product in locations where the temperature or humidity exceeds the ratings or where condensation may occur. When installing the product in a panel, be sure that the temperature around the product (not the temperature around the panel) does not exceed the ratings. The product service life depends on the ambient temperature. The higher the ambient temperature, the shorter the service life. To extend the product service life, lower the temperature inside the Temperature Meter.
- Use and store the product within the temperature and humidity ranges given in the specifications. When gang-mounting Temperature Meters or arranging them vertically, heat generated by the Temperature Meters will cause the internal temperature to rise, reducing the service life. In such cases, consider forced cooling methods, such as using a fan to circulate air around the Temperature Meters. Do not, however, allow only the terminals to be cooled. Doing so will increase measurement error.
- The life of the output relays are greatly affected by the switching capacity and switching conditions. Use these relays within their rated load and electrical life. The contacts may fuse or burn if they are used past their electrical life.



## Parameters

- Note:**
1. Some parameters are not displayed for certain models.
  2. The K3MA-L will stop measurement if the level is changed to the initial setting level or the advanced-function setting level.
  3. If the input range is changed, some parameters are set to default values. Therefore, set the input range first.
  4. Settings displayed in reversed colors are defaults.

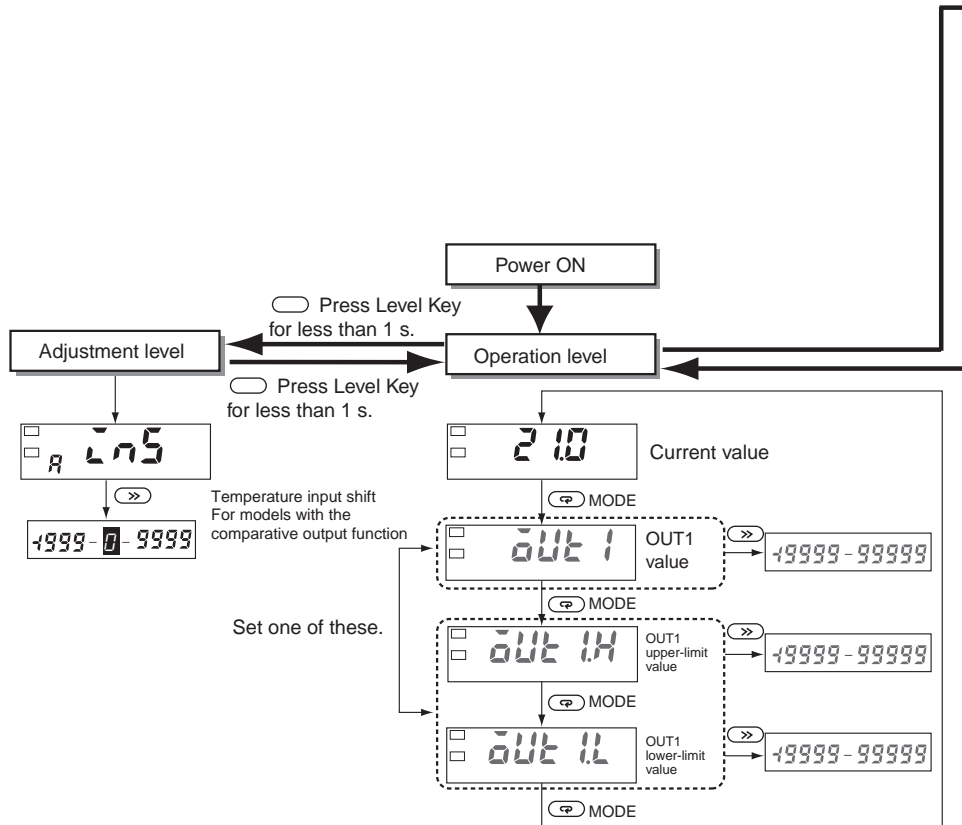



Press Level Key  for more than 3 s.

Press Level Key  for less than 1 s.

Press Level Key  for more than 1 s.

Enter password "-0169"

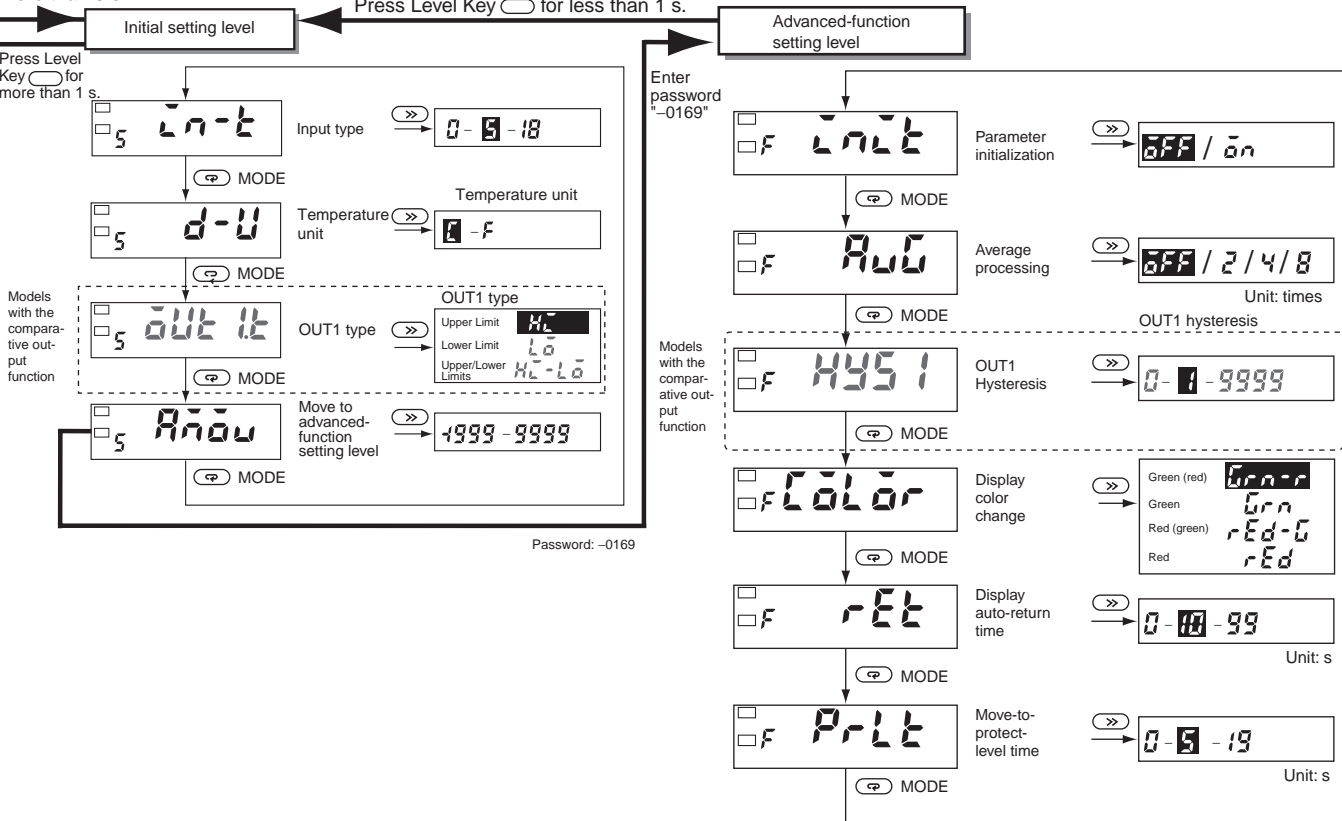

Password: -0169

Settings displayed in reversed colors are initial settings.

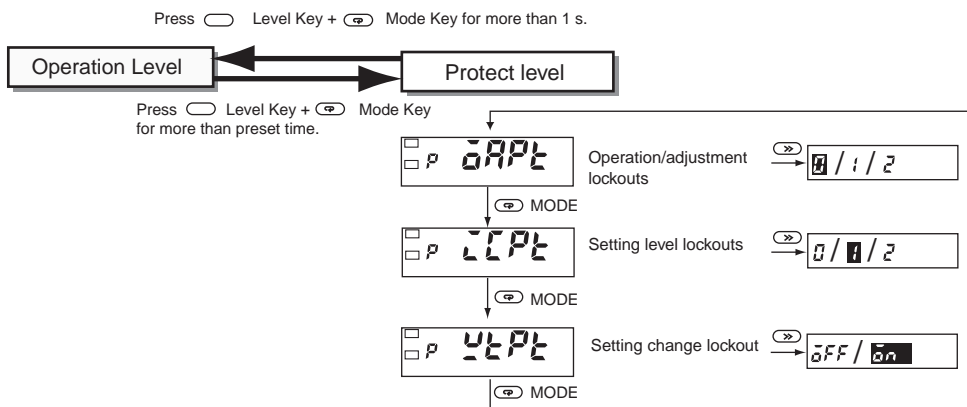

## Operation/Adjustment Lockouts

Restricts key operations for operation level and adjustment level.

Parameter	Setting	Operation level		Moving to adjustment level
		Process value display	Set value display	
0APL	0	Allowed	Allowed	Allowed
	1	Allowed	Allowed	Prohibited
	2	Allowed	Prohibited	Prohibited

- Initial setting is 0.
- This cannot be displayed on models not equipped with the comparative output function.

## Setting Level Lockouts

Restricts shifting to initial setting level or advanced-function setting level.

Parameter	Setting	Shift to initial setting level	Shift to advanced-function setting level
1APL	0	Allowed	Allowed
	1	Allowed	Prohibited
	2	Prohibited	Prohibited

## Setting Change Lockout

Restricts setting changes by key operation. When this lockout is set, it is no longer possible to shift to a setting change mode.

Parameter	Setting	Setting change by key operation
2APL	0FF	Allowed
	0n	Prohibited

However, all protect level parameters can still be changed.

## Initial Settings

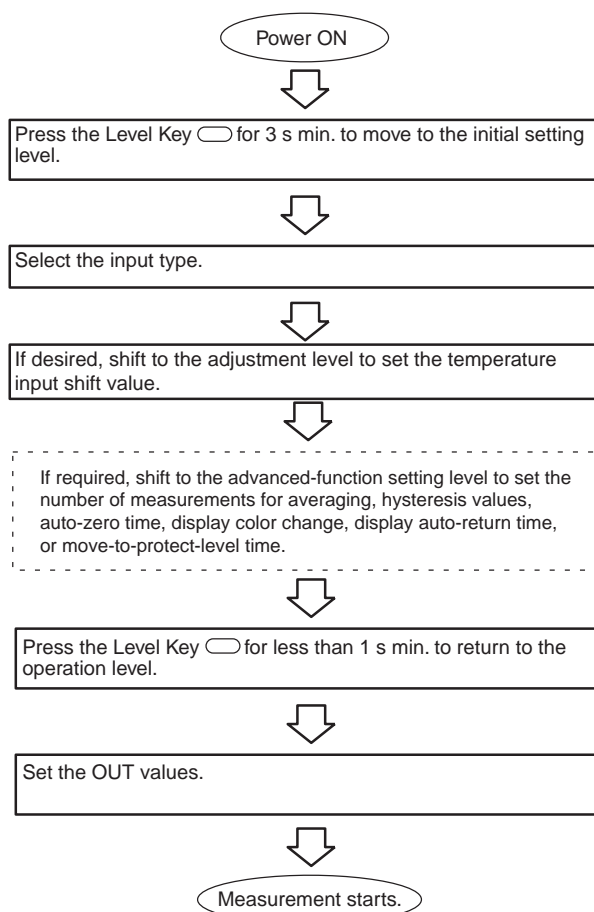

## ■ Setting Example

### Initial Settings

The settings for the following example are shown here.

#### Example: Monitoring the temperature of an industrial furnace

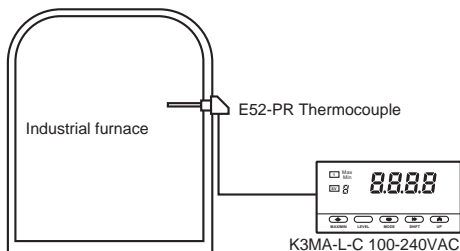

Here, the temperature inside the furnace is to be displayed in centigrade (°C).  
 Temperature sensor: E52-PR Thermocouple, Measurement range: 0 to 1,400°C.

1. Set the K3MA-L input type to the thermocouple R input range.  
 Parameter: *cn-t* (input type), Setting value: *15*
2. Select centigrade (°C) as the temperature unit.  
 Parameter: *d-U* (temperature unit), Setting value: *1*

If you are using a comparative output model, make the setting as desired.

## ■ Troubleshooting

When an error occurs, error details will be displayed on the main indicator. Confirm the error from the main indicator and take the appropriate countermeasures.

Level display	Main indicator	Error contents	Countermeasures
Not lit	<i>E111</i>	RAM memory error	Repair is necessary. Consult your OMRON sales representative.
<i>5</i>	<i>E111</i>	EEPROM memory error	When this error is displayed, press the Level Key for 3 seconds, and the settings will be restored to the factory settings. If the error cannot be recovered, repair is necessary. Consult your OMRON sales representative.
Not lit	Flashes <i>5Err</i>	Input error	Confirm that the temperature sensor is correctly connected, and that there are no broken signal lines to the temperature sensor. If the condition does not return to normal, repair is necessary. Consult your OMRON sales representative.
Not lit	Flashes <i>9999</i>	The measurement value after temperature input correction exceeds 9999.	The temperature input correction value may be inappropriate. Use the adjustment level to review the temperature input correction value.
Not lit	Flashes <i>-1999</i>	The measurement value after temperature input correction is lower than -1999.	The temperature input correction value may be inappropriate. Use the adjustment level to review the temperature input correction value.

## Warranty and Limitations of Liability

---

### ■ WARRANTY

OMRON's exclusive warranty is that the products are free from defects in materials and workmanship for a period of one year (or other period if specified) from date of sale by OMRON.

OMRON MAKES NO WARRANTY OR REPRESENTATION, EXPRESS OR IMPLIED, REGARDING NON-INFRINGEMENT, MERCHANTABILITY, OR FITNESS FOR PARTICULAR PURPOSE OF THE PRODUCTS. ANY BUYER OR USER ACKNOWLEDGES THAT THE BUYER OR USER ALONE HAS DETERMINED THAT THE PRODUCTS WILL SUITABLY MEET THE REQUIREMENTS OF THEIR INTENDED USE. OMRON DISCLAIMS ALL OTHER WARRANTIES, EXPRESS OR IMPLIED.

### ■ LIMITATIONS OF LIABILITY

OMRON SHALL NOT BE RESPONSIBLE FOR SPECIAL, INDIRECT, OR CONSEQUENTIAL DAMAGES, LOSS OF PROFITS, OR COMMERCIAL LOSS IN ANY WAY CONNECTED WITH THE PRODUCTS, WHETHER SUCH CLAIM IS BASED ON CONTRACT, WARRANTY, NEGLIGENCE, OR STRICT LIABILITY.

In no event shall the responsibility of OMRON for any act exceed the individual price of the product on which liability is asserted.

IN NO EVENT SHALL OMRON BE RESPONSIBLE FOR WARRANTY, REPAIR, OR OTHER CLAIMS REGARDING THE PRODUCTS UNLESS OMRON'S ANALYSIS CONFIRMS THAT THE PRODUCTS WERE PROPERLY HANDLED, STORED, INSTALLED, AND MAINTAINED AND NOT SUBJECT TO CONTAMINATION, ABUSE, MISUSE, OR INAPPROPRIATE MODIFICATION OR REPAIR.

## Application Considerations

---

### ■ SUITABILITY FOR USE

OMRON shall not be responsible for conformity with any standards, codes, or regulations that apply to the combination of products in the customer's application or use of the products.

At the customer's request, OMRON will provide applicable third party certification documents identifying ratings and limitations of use that apply to the products. This information by itself is not sufficient for a complete determination of the suitability of the products in combination with the end product, machine, system, or other application or use.

The following are some examples of applications for which particular attention must be given. This is not intended to be an exhaustive list of all possible uses of the products, nor is it intended to imply that the uses listed may be suitable for the products.

- Outdoor use, uses involving potential chemical contamination or electrical interference, or conditions or uses not described in this catalog.
- Nuclear energy control systems, combustion systems, railroad systems, aviation systems, medical equipment, amusement machines, vehicles, safety equipment, and installations subject to separate industry or government regulations.
- Systems, machines, and equipment that could present a risk to life or property.

Please know and observe all prohibitions of use applicable to the products.

NEVER USE THE PRODUCTS FOR AN APPLICATION INVOLVING SERIOUS RISK TO LIFE OR PROPERTY WITHOUT ENSURING THAT THE SYSTEM AS A WHOLE HAS BEEN DESIGNED TO ADDRESS THE RISKS, AND THAT THE OMRON PRODUCTS ARE PROPERLY RATED AND INSTALLED FOR THE INTENDED USE WITHIN THE OVERALL EQUIPMENT OR SYSTEM.

**ALL DIMENSIONS SHOWN ARE IN MILLIMETERS.**

To convert millimeters into inches, multiply by 0.03937. To convert grams into ounces, multiply by 0.03527.

Cat. No. N109-E1-04 **In the interest of product improvement, specifications are subject to change without notice.**

### OMRON Corporation

Industrial Automation Company

Industrial Devices and Components Division H.Q.

Measuring Components Department

Shiokoji Horikawa, Shimogyo-ku,

Kyoto, 600-8530 Japan

Tel: (81)75-344-7080/Fax: (81)75-344-7189

Printed in Japan

0703-0.3M (1001) (B)